



# PRRS-7367



## General Application

PRRS-7367 is a numerical distributed protection intended for protecting and monitoring various primary apparatus including overhead line, underground cable, transformer, capacitor, etc. PRRS-7367 can be used in various voltage level.



❖ Front Panel

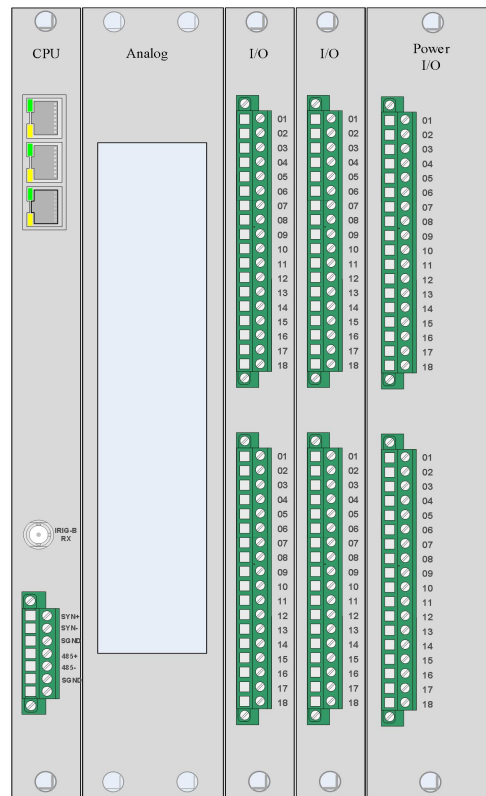

❖ Rear Panel

## Feature

Item	Parameter
Performance	32-bit high performance dual-core processor, internal high speed bus and intelligent I/O ports
Hardware	Modularized hardware design, flexibly configurable, easy extension
Interface	HMI with a control module (a 320×240-dot LCD, 16-key keypad and 28 LED indicators)
Communication	Ethernet network, RS-485 serial ports. Communication protocol optional: IEC61850, IEC60870-5-103, DNP3.0 or ModBus.
Time Synchronization	SNTP, IEEE 1588, pulse per second (PPS) and IRIG-B
Analog	Support the protocol IEC60044-8, IEC61850-9-2 and GOOSE, constantly measures and calculates voltage, current, power and frequency.
Recording	Fault and disturbance waves, operation reports, supervision, control operation records and time tagged sequence of event.
Monitor & Control	BI, BO, measurement and control

## Protection Functions

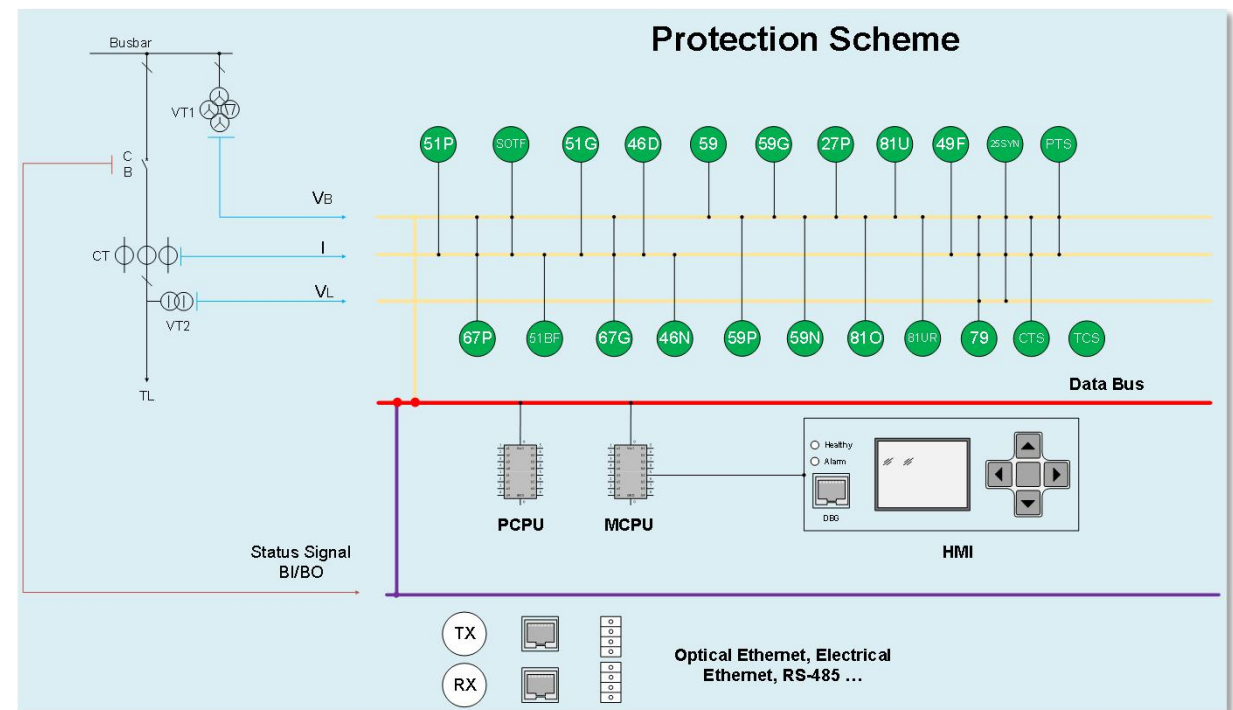

## Protection Functions

Description	IEC 60617	ANSI	CYG Code
Non-directional overcurrent protection	3I>	50/51P	50/51P/51PV T
Directional overcurrent protection	3I> ->	67P	67P
Non-directional earth-fault protection	Io>	50/51N	50/51G/51G VT
Directional earth-fault protection	Io>->	67N	67G
Switch onto fault	SOTF	SOTF	SOTF
Circuit breaker failure protection	3I>/IO>BF	50BF	50BF
Three-phase thermal overload protection	3Ith>	49	49F
Phase discontinuity protection	I2/I1>	46PD	46D
Negative sequence current protection	I2>	46N	46N
Three-phase overvoltage protection	3U>	59	59
Positive sequence overvoltage protection	U1>	47	59P
Residual overvoltage protection	Uo>	59G	59G
Negative sequence overvoltage protection	U2>	47	59N
Positive sequence undervoltage protection	U1<	47	27P
Overfrequency protection	f>	81	81O
Underfrequency protection	f<	81	81URS
Underfrequency restore protection	-	-	81URE
Frequency gradient protection	Df/dt<>	81	81R
Auto-reclose	O ->I	79	79
Synchrocheck	SYNC	25	25SYN
Current unbalance protection	dI>C	51NC-1	51NA
Three phase current unbalance protection	3dI>C	51NC-2	51NT
Voltage unbalance protection	PQUUB	PQUUB	59NA
Three phase voltage unbalance protection	PQUUB	PQUUB	59NT
Fault locator	FLOC	21FL	21FL
Three phase under voltage protection of capacitor	3U<	27	CUB_27

## Protection Functions

Description	IEC 60617	ANSI	CYG Code
Power protection	P>	32R/32O/32 U	32
Reverse power protection	P or Q>	32R/32O	32R
Voltage Selection	/	/	/
Mechanical protection			MP
Trip Logic	/	94	94T
Close Logic	/	/	Close Logic
Backup power automatic switch	/	/	BPAS
Wattmetric sensitive earth fault	/	/	SEF
Under current protection	/	37	37C
Block Busbar protection	/	/	Block Busbar
Gap current zero sequence voltage protection	/	/	Gap
Restricted Earth Fault Protection (64REF)	IdN/I	87NL	64REF
Faulty Phase Selection	/	/	FPS
Stabilized differential protection for machines	3dI>G/M	87M	87MPDIF
Flux-balance based differential protection for machines	3dIH>G/M	/	87MFDIF
Machine Startup	/	/	MST
Long start protection	/	/	MQDS
The locked-rotor protection	/	/	MDZS
Synchronous Motor Loss of Step	/	/	78O
Synchronous Motor Loss of Excitation	/	/	40O

## Supervision Functions

Description	IEC 60617	ANSI	CYG Code
Current circuit supervision	MCS 3I	MCS 3I	CTS
Fuse failure supervision	FUSEF	60	PTS
Trip circuit supervision	TCS	TCM	TCS

## Protection Specifications

### Overcurrent Protection

Operate current	$\pm 1.0\%$ of the set value or $\pm 0.005 \times I_n$
Blocking voltage	$\pm 1.0\%$ of the set value or $\pm 0.005 \times U_n$
Reset time	$\leq 45\text{ms}$
Reset ratio	Typically $96\%(\pm 3\%)$ , Or $(\pm 3\%)$
Tolerance of operating time at instantaneous time mode without directional and voltage control element	$\leq 25\text{ ms}$ at $I=2 \times I_{\text{start}}$ value
Tolerance of operating time at definite time mode	$\pm 1.0\%$ of the set value or $\pm 40\text{ ms}$
Tolerance of operating time at inverse time mode	$\pm 5.0\%$ of the theoretical value or $\pm 40\text{ ms}$ , Start value multiples in range of 1.2...20 when $I > I_n$ , Start value multiples in range of 2...20 when $I \leq I_n$ .
DIR criteria	$\leq \pm 2^\circ$
Transient overreach accuracy (Only for Indonesia)	$< 10\%$
Transient accuracy overshoot	$\leq 40\text{ms}$

### Residual Overcurrent Protection

Operate current	$\pm 1.0\%$ of the set value or $\pm 0.005 \times I_n$
Blocking voltage	$\pm 1.0\%$ of the set value or $\pm 0.005 \times U_n$
Reset time	$\leq 45\text{ms}$
Reset ratio	Typically $96\%(\pm 3\%)$ , Or $(\pm 3\%)$
Tolerance of operating time at instantaneous time mode without directional and voltage control element	$\leq 25\text{ ms}$ at $I=2 \times I_{\text{start}}$ value
Tolerance of operating time at definite time mode	$\pm 1.0\%$ of the set value or $\pm 40\text{ ms}$
Tolerance of operating time at inverse time mode	$\pm 5.0\%$ of the theoretical value or $\pm 40\text{ ms}$ , Start value multiples in range of 1.2...20 when $I > I_n$ , Start value multiples in range of 2...20 when $I \leq I_n$ .
Transient overreach accuracy (Only for Indonesia)	$< 10\%$
Transient accuracy overshoot	$\leq 40\text{ms}$

## Protection Specifications

### Sequence Overcurrent Protection

Tolerance of operating current	$\pm 1.0\%$ of the set value or $\pm 0.005 \times I_n$
Reset time	$\leq 45\text{ms}$
Reset ratio	Typically $96\%(\pm 3\%)$ , Or $(\pm 3\%)$
Tolerance of operating time at definite time mode	$\pm 1.0\%$ of the set value or $\pm 40\text{ ms}$
Tolerance of operating time at inverse time mode	$\pm 5.0\%$ of the theoretical value or $\pm 40\text{ ms}$ , Start value multiples in range of 1.2...20 when $I > I_n$ , Start value multiples in range of 2...20 when $I \leq I_n$ .
Transient overreach accuracy (Only for Indonesia)	$< 10\%$
Transient accuracy overshoot	$\leq 40\text{ms}$

### Phase Discontinuity Protection

Tolerance of Ratio setting	$\pm 2\%$ of the set value
Reset time	$\leq 45\text{ms}$
Current Reset ratio	Typically $96\%(\pm 3\%)$ , Or $(\pm 3\%)$
Tolerance of operating time at definite time mode	$\pm 1.0\%$ of the set value or $\pm 40\text{ ms}$

### Over/Under Frequency Protection

Tolerance of operating frequency	$\pm 0.01\text{Hz}$ , 30.00-70.00 at $F_n=50$ ; 40.00-80.00 at $F_n=60$
Tolerance of blocking voltage	$\pm 1.0\%$ of the set value or $\pm 0.005 \times U_n$
Tolerance of frequency gradient	$\pm 0.1\text{Hz/s}$ at $-10.00 \sim 10.00\text{ Hz/s}$
Operate time, definite time function	$\pm 1.0\%$ of the set value or $\pm 60\text{ ms}$
Reset time, definite time function	$< 190\text{ms}$

### Over/Under Voltage Protection

Tolerance of operating voltage	$\pm 1.0\%$ of the set value or $\pm 0.005 \times U_n$
Tolerance of blocking current	$\pm 1.0\%$ of the set value or $\pm 0.005 \times I_n$
Reset ratio	$\leq 96\%(\pm 3\%)$
Tolerance of operating time at definite time mode	$\pm 1.0\%$ of the set value or $\pm 40\text{ ms}$
Tolerance of operating time at inverse time mode	$\pm 5.0\%$ of the theoretical value or $\pm 40\text{ ms}$ , the maximum Start value is $1.2U_n$ , the Start value multiples in range of 1.10...2.00.

## Protection Specifications

### Power Protection

Operation accuracy	At the frequency $f = f_n$ Power: $\leq 2.5\%$ Setting or 0.5W
Reset ratio	$\leq 96\%$ ( $\pm 3\%$ )
Tolerance of operating time	$\pm 1.0\%$ of the set value or $\pm 40$ ms

### 50BF Protection

Operate current	$\pm 1.0\%$ of the set value or $\pm 0.005 \times I_n$
Operate residual current	$\pm 1.0\%$ of the set value or $\pm 0.005 \times I_n$
Current Reset ratio	Typically $96\%$ ( $\pm 3\%$ ), Or $(\frac{SetValue - 0.005I_n}{SetValue})(\pm 3\%)$
Drop-off time	$\leq 12.5$ ms
Tolerance of operating time	$\pm 1.0\%$ of the set value or $\pm 40$ ms

### Thermal overload

Operate current	$\pm 1.0\%$ of the set value or $\pm 0.005 \times I_n$ at 0.04...3In
$t = \tau \times \ln \frac{I^2 - \theta_t(k \cdot I_B)^2}{I^2 - \theta_{t+1}(k \cdot I_B)^2}$	IEC 60255-8, $\pm 5\% + 200$ ms

### Auto-Reclose

Tolerance of operating time	$\pm 1.0\%$ of the set value or $\pm 40$ ms
-----------------------------	---

### OCR\_INR

Operate accuracy	Current measurement: $\pm 1.0\%$ of the set value or $\pm 0.005 \times I_n$ Ratio I2Hp/lp measurement: $\pm 5.0\%$ of the set value
Operating time accuracy	$\pm 1.0\%$ of the set value or $\pm 40$ ms
Reset time	$\leq 45$ ms
Reset ratio	(Ratio setting-0.005)/ Ratio setting( $\pm 3\%$ )

## Protection Specifications

### Sensitive Earth Fault

Operate accuracy	Current measurement: $\pm 1.0\%$ of the set value or $\pm 0.005 \times I_n$ Voltage measurement: $\pm 1.0\%$ of the set value or $\pm 0.005 \times U_n$ Power measurement: $\pm 3.0\%$ of the set value or $\pm 0.002 \times S_n$
Tolerance of operating time at definite time mode	$\pm 1.0\%$ of the set value or $\pm 40$ ms
Tolerance of operating time at inverse time mode	$\pm 5.0\%$ of the theoretical value or $\pm 40$ ms
Reset time	$\leq 45$ ms
Reset ratio	Typically $96\%$ ( $\pm 3\%$ ), Or $(\pm 3\%)$

### Gap overcurrent and zero sequence overvoltage

Operate current	$\pm 1.0\%$ of the set value or $\pm 0.005 \times I_n$
Operate voltage	$\pm 1.0\%$ of the set value or $\pm 0.005 \times U_n$
Reset time	$\leq 60$ ms
Current Reset ratio	Typically $96\%$ ( $\pm 3\%$ ), Or $(\frac{SetValue - 0.005I_n}{SetValue})(\pm 3\%)$
Voltage Reset ratio	Typically $96\%$ ( $\pm 3\%$ )
Tolerance of operating time	$\pm 1.0\%$ of the set value or $\pm 40$ ms

### Restricted Earth Fault Protection 64REF

Operate current	$\pm 1.0\%$ of the set value or $\pm 0.005 \times I_n$
Reset ratio	Typically $96\%$ ( $\pm 3\%$ ), Or $(\frac{SetValue - 0.005I_n}{SetValue})(\pm 3\%)$
Tolerance of operating time	$\pm 1.0\%$ of the set value or $\pm 40$ ms

### Differential Protection

Operate current	$\pm 1.0\%$ of the set value or $\pm 0.005 \times I_n$
Reset time	$\leq 45$ ms
Reset ratio	Typically $96\%$ ( $\pm 3\%$ ), Or $(\frac{SetValue - 0.005I_n}{SetValue})(\pm 3\%)$
Tolerance of operating time	$\pm 1.0\%$ of the set value or $\pm 40$ ms
Transient accuracy overshoot	$\leq 40$ ms