

Intelligent Edge Computing Monitoring Terminal

Demand Background

Currently, the distribution network is facing many pressures such as fast development and change speed, **multi-level service demand** of customers, **high dependence** of customers on **electricity**, **high pressure on clean energy consumption** and high impact of variable loads such as **electric vehicle charging piles**, etc. The traditional management mode of the distribution network can no longer satisfy the development demand of the distribution network in the new period, and there is an urgent need to deeply apply advanced technologies such as “cloud computing, big data, internet of things, mobile internet and smart city” to essentially improve the **construction, operation and management level of distribution network**, realize leapfrog development and meet the demand of “re-electrification” of energy transformation.

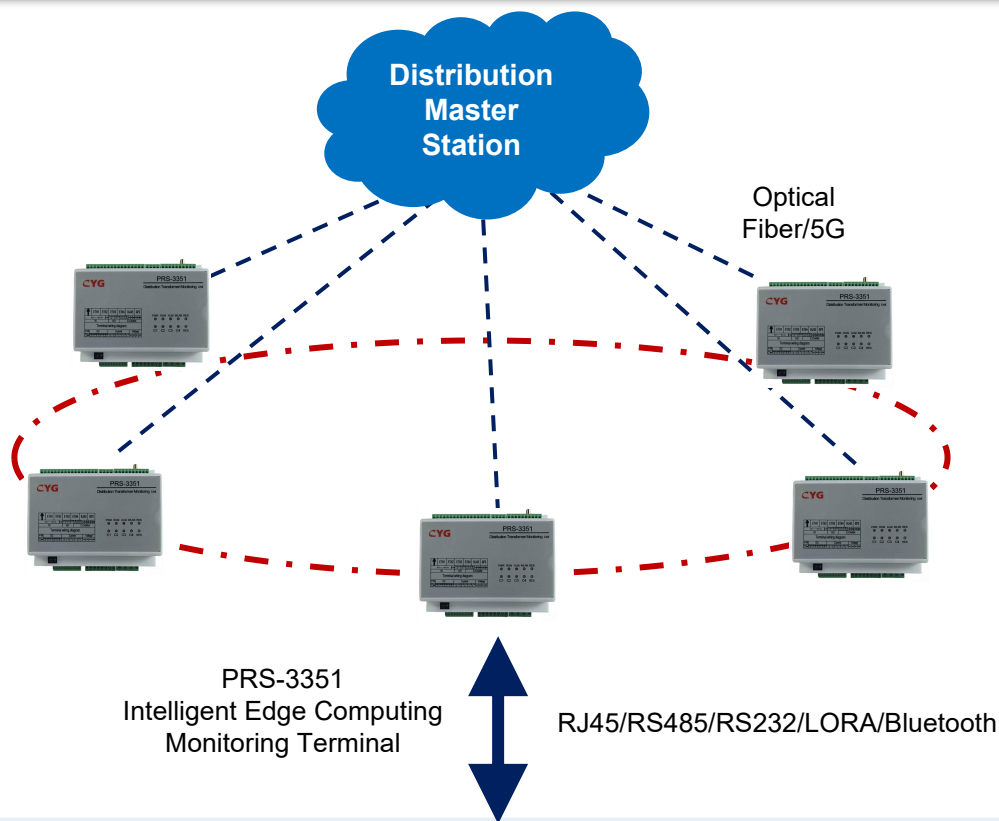

Distribution Transformer Management

Electricity Meter Reading Management

Low Voltage Side Equipment Management

New Energy Management

Auxiliary Monitoring System Management

Intelligent Edge Computing Monitoring Terminal

Introduction



PRS-3351 intelligent edge computing monitoring terminal adopts the domestic quad-core CPU with low power consumption, adapting to industrial-grade scenarios. Meanwhile, it supports integrated security chip, single-channel identity authentication and data encryption and decryption processing, to meet the conversion of the interaction protocol between the terminal and the master station and the requirements for security protection, and protects the application and information security of the intelligent edge computing monitoring terminal from a multi-dimensional perspective.

Serial Number	Item	Performance Parameters
1	Rated Voltage	<ul style="list-style-type: none"> DC5V
2	Terminal Backup Power Supply	<ul style="list-style-type: none"> The terminal adopts external lithium battery as backup power supply. When the external main power supply fails, the lithium battery can be automatically and seamlessly put into operation, maintaining the terminal and the external communication module in full-function normal operation for more than 2 hours; When the power supply is lost, the terminal can save the setting values and recorded data for more than 1 year;
3	Measurement Capacity	<ul style="list-style-type: none"> Acquisition of three-phase phase voltage and current; four groups of switching variable signals can be acquired;
4	CPU Frequency	<ul style="list-style-type: none"> 1.2GHz quad-core
5	Memory	<ul style="list-style-type: none"> 1GByte
6	FLASH	<ul style="list-style-type: none"> 8GByte
7	Ethernet port	<ul style="list-style-type: none"> Equipped with 4 RJ-45 Ethernet communication interfaces for remote communication and local maintenance.
8	RS-232/RS-485	<ul style="list-style-type: none"> Equipped with 2 RS-485 communication interfaces, 2 RS-232 communication interfaces, with selectable communication rates.
9	Bluetooth	<ul style="list-style-type: none"> With 1-channel Bluetooth interface, supporting Bluetooth 4.2 and above versions, and concurrent communication with 2 hosts and 3 slaves.
10	WIFI	<ul style="list-style-type: none"> The terminal has 1-channel Wi-Fi for local operation and maintenance equipment;
11	GPS	<ul style="list-style-type: none"> The terminal has 1-channel GPS interface for local geographical location information acquisition and timing.
12	Status Quantity Input Interface	<ul style="list-style-type: none"> Software anti-jitter time 100 ~ 60000 ms can be set, and the event recording resolution is no more than 2 ms; Signal input mode: passive contact.
13	Electric Energy Pulse Output Interface	<ul style="list-style-type: none"> With a second pulse output interface, and active and reactive photoelectric pulse output interface.
14	Service Life	<ul style="list-style-type: none"> The average trouble-free working time (MTBF) of the equipment body is no less than 50,000h; the service life of the terminal is 8 to 10 years.

Application Scenarios



Distribution Transformer Monitoring



Power Meter Reading



Equipment Management



Charging Management



New Energy Management



Energy Storage Management



Station Monitoring



Robot Inspection



Remote Operation and Maintenance

General Functional Scenarios

- ✓ General monitoring of electrical power consumption at the distribution transformer supply zone
- ✓ Meter reading management for power usage in the transformer supply zone
- ✓ Monitoring and management of low-voltage side equipment (circuit breaker, load monitoring terminal, etc.) in the transformer supply zone
- ✓ In charging pile scenarios, information on the status of charging piles and charging/discharging amount
- ✓ Monitoring of equipment status and energy quality in distributed new energy scenarios.
- ✓ Monitoring and management of energy storage converters and battery compartments in the transfer supply zone energy storage scenario

Auxiliary Control Function Scenarios

- ✓ Monitoring the environment and equipment status information of the whole area in the intelligent station scenario
- ✓ Intelligent robot scenario for robot equipment status information
- ✓ Supporting remote tablet information viewing, operation and maintenance

Intelligent Edge Computing Monitoring Terminal

Functional Value

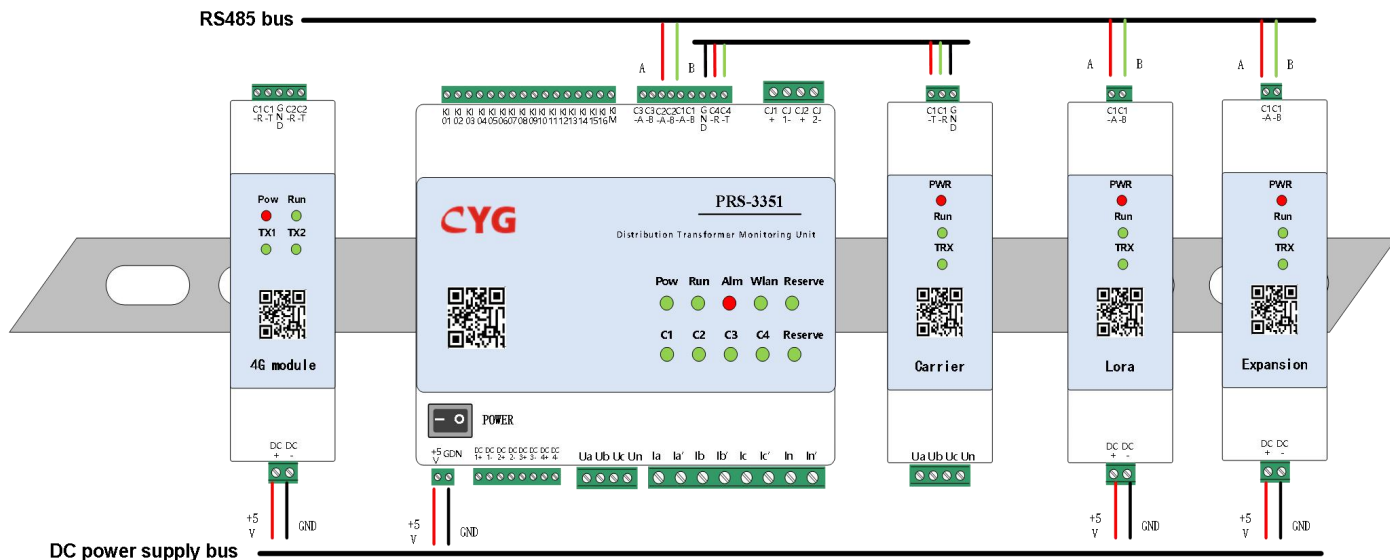

Serial Number	Device Function	Performance Parameters
1	Platform Software Function	<ul style="list-style-type: none"> Including equipment management, log management
3	Data Acquisition	<ul style="list-style-type: none"> Real-time acquisition of distribution substation LV side data, LV outgoing line, cable branch data, transformer status, environmental status, and power quality equipment acquisition.
4	Data Recording	<ul style="list-style-type: none"> Real-time recording of analog data acquisition, and the formation of 15min data curve according to the requirements of the configuration to send, curve records can be saved for 1 year.
5	Electrical Alarm	<ul style="list-style-type: none"> Including voltage loss alarm, three-phase imbalance alarm, line phase break alarm, power failure alarm, heavy load/overload alarm, etc.
6	Transformer Supply Zone Low-voltage Equipment Management	<ul style="list-style-type: none"> Including low-voltage topology identification, fault research and judgment, the line loss analysis of transfer supply zone, the phase identification of transfer supply zone, etc.
7	Intelligent Monitoring of Distribution Room	<ul style="list-style-type: none"> Unified monitoring of low-voltage side electrical quantity monitoring system, transformer monitoring system, equipment status monitoring system, environmental monitoring system, intelligent security system and video monitoring system, etc.
8	Charging Pile Orderly Charging Management	<ul style="list-style-type: none"> Assist in accomplishing charging pile orderly charging management: charging status monitoring, charging plan issuance, and charging management.
9	Distributed Energy Access Management	<ul style="list-style-type: none"> Assist in accomplishing distributed energy access management: monitoring of grid-connected point information, data statistics of grid-connected points; assist in grid-connected point management: over-voltage/low-voltage identification, over-frequency/low-frequency identification, islanding protection assistance.

