

PRS-7342 New Energy Intelligent Integrated Box Transformer Terminal Technical User Manual

Ver 1.01.202508

CYG Technology Group Co., Ltd.

CYG SUNRI CO., LTD.

**PRS-7342 New Energy Intelligent
Integrated Box Transformer Terminal
Technical User Manual**

Ver 1.01.202508

CYG Technology Group Co., Ltd.

CYG SUNRI CO., LTD.

This manual applies to the PRS-7342 New Energy Intelligent Integrated Box Transformer Terminal with program version V1.00 and above.

This technical user manual is compiled and published by CYG Technology Group Co., Ltd. and CYG SUNRI CO., LTD. Therefore, we reserve the right to the final interpretation of related products.

We are sincerely sorry for that related products subsequently upgraded may be slightly different from those in the manual and the manual may be upgraded without prior notice. Please pay attention to the discrepancy between actual products and corresponding description in this manual. Please pay attention to the discrepancy between actual products and corresponding description in this manual.

For more information about the products, please visit the website: <http://www.sznari.com>

Free customer service hotline: 400-678-8099

Table of Contents

1. Overview	1
1.1. Application Scope	1
1.2. System features	2
1.3. Main functions	3
1.4. Design specifications	4
2. Technical parameters	7
2.1. Mechanical and environmental parameters	7
2.2. Rated electrical parameters	7
2.3. Main technical indicators	8
2.4. Electromagnetic compatibility	9
2.5. Insulation test	10
2.6. Mechanical performance	11
3. Device functions and principles	12
3.1. Telemetry, remote signaling, remote control	12
3.2. Parameter setting function	13
3.3. Device self-test function	13
3.4. Time synchronization function	14
3.5. Data storage function	14
3.6. Communication function	14
3.7. Fiber optic ring network switching	15
3.8. Data forwarding function	15
3.9. Debugging function	15
3.10. Function and principle of relay protection	16
4. Device setting value	26
4.1. Device setting value	26
5. Structure and external characteristics	34
5.1. Opening size	34
5.2. External characteristic definition	35
6. Device order description	39
6.1. Basic ordering parameters	39

Appendix A Device usage instructions	40
A.1. Panel layout and display	40
A.2. Menu interface operation instructions	41
Appendix B Device debugging and commissioning instructions	44
B.1 Preparation of debugging materials	44
B.2 Check before power on	44
B.3 Power-on check	44
B.4 Whole machine debugging	45
B.5 Operation steps for putting the device into operation	46
B.6 Device operation instructions	46
Appendix C Differential protection setting calculation	47
C.1 CT wiring principle	47
C.2 Differential current calculation formula	47
C.3 Transformer star connection phase compensation	47
C.4 Calculation of rated current I_e for longitudinal differential protection	48
C.5 Calculation of longitudinal differential CT balance coefficient	49
Appendix D Protection setting value error range	51
D.1 Three-stage directional overcurrent protection	51
D.2 Two-stage negative-sequence overcurrent protection	51
D.3 Three-stage zero-sequence directional overcurrent protection	51
D.4 Low-voltage protection	52
D.5 Overvoltage protection	52
D.6 Zero-sequence overvoltage protection	52
D.7 Non electricity protection	52
D.8 Longitudinal differential protection	53

1. Overview

1.1. Application Scope

PRS-7342 new energy intelligent integrated box transformer terminal series device is applicable when the access voltage is 800 V and below (including 100 V/220 V/380 V/690 V/800 V, etc.). It is suitable for new-energy power stations (photovoltaic power plants and wind farms) of various installed capacities, and can realize the protection, measurement and control, communication management, and optical fiber ring network functions of the local units in the photovoltaic power generation area and wind turbines.

Table 1-1-1 Functional description of PRS-7342 new energy intelligent integrated box transformer terminal series device

Model	Function description
PRS-7342	<p>It is suitable for one photovoltaic array in the photovoltaic power generation area of a photovoltaic power plant, or one wind turbine and its supporting box-type step-up transformer in a wind farm. It includes at least the following functions:</p> <ol style="list-style-type: none"> 1. Measurement and control of the box-type step-up transformer, and a full set of electrical and non electricity protection functions. It supports two-winding or three-winding transformers in various wiring forms. 2. Communication access to various intelligent devices. It is equipped with various communication interfaces such as Ethernet ports, RS-485, and RS-232. A rich protocol library ensures the seamless access of intelligent devices. 3. Fiber optic ring network switching function. It comes standard with 2 pairs of gigabit optical ports to achieve fiber optic self-healing network communication of the local terminal devices in the new-energy power station

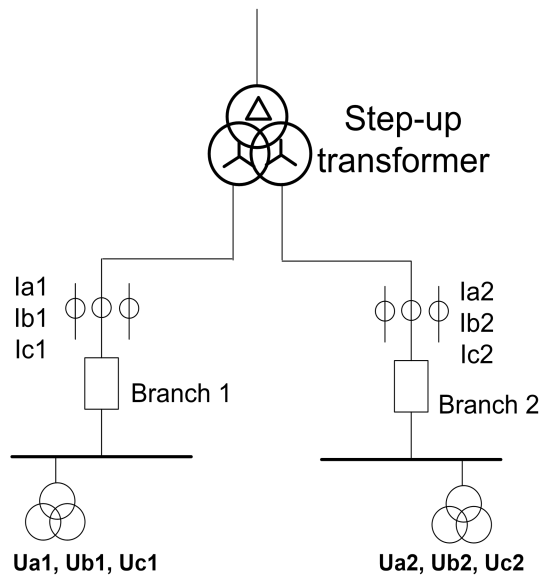

Figure 1-1-1 Schematic Diagram of the Main Wiring of the Double-Split Box-Type Transformer

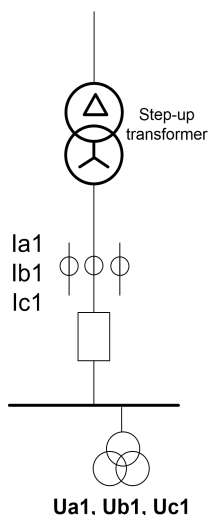

Figure 1-1-2 Schematic Diagram of the Main Wiring of the Double-Winding Box-Type Transformer

1.2. System features

PRS-7342 new energy intelligent integrated box transformer terminal has the following features:

- 1) The device adopts the hardware platform with the latest generation bus structure in the power industry.

This hardware platform has a plug-in structure. Each plug-in module is equipped with an intelligent unit. Data interaction among modules is carried out based on the communication bus. It supports hot-swapping and features low power consumption, easy expansion, and high reliability. The main CPU plug-in adopts a powerful quad-core ARM Cortex-A7 CPU, which has strong computing ability and is easy to expand functions. In addition, in order to solve the problem that measurement accuracy is easily affected in extreme high and low temperature environments, the device adopts high-precision acquisition devices and intelligent temperature compensation strategies to achieve high measurement accuracy.

- 2) The device is equipped with complete protection function modules and has wide adaptability in the industry.

The device is designed to fully meet the industry standards, national grid standards, and standards of China Southern Power Grid, as well as other industry and enterprise standards and specifications. It has wide-ranging industry adaptability. The relevant standards and specifications include, but are not limited to, GBT 19964-2012 Technical Requirements for Connecting Photovoltaic Power Station to Power System and GBT_50866-2013 Design Code for Photovoltaic Power Station Connecting to Power System.

- 3) The device has a complete event record and is highly maintainable.

The device uses a large-capacity storage device, which can fully record various protection action records, input status records, self-test and device abnormality records, operation and operation records, and wave recording records.

- 4) The device has powerful and rich communication functions and has strong communication compatibility.

The device has a large number of various communication interfaces. With the help of a rich and complete protocol library, it can connect to various intelligent devices such as inverters, intelligent combiner boxes, and wind turbine monitors at the lower level, and transmit various collected and communication data at the upper level.

- 5) The device has the function of a fiber optic ring network switch and offers a highly reliable communication networking solution.

The two sets of fiber optic interfaces can realize the fiber optic self-healing network communication of the local terminal devices in the new-energy power station, and the highly reliable redundant communication network greatly optimizes the local communication cost and communication quality.

1.3. Main functions

The PRS-7342 new energy intelligent integrated box transformer terminal adopts a modular design method and an object-oriented design concept. It is installed near the controlled primary equipment and has functions such as information collection, event recording, time calibration, remote maintenance, parameter setting, data storage, self-diagnosis and self-recovery, data forwarding and communication, fault detection and protection, execution of remote control commands, and device networking communication.

The PRS-7342 new energy intelligent integrated box transformer terminal completes the information collection and control of the controlled object. It can send information to the monitoring system through the communication system and receive control commands from the monitoring system;

The PRS-7342 new energy intelligent integrated box transformer terminal has complete local and remote maintenance functions. It has standard RS232, RS485 and Ethernet communication interfaces, which can perform program replacement, parameter modification, and setting value downloading locally or remotely.

The PRS-7342 new energy intelligent integrated box transformer terminal has a complete communication protocol library, and can freely select communication protocols, supporting common protocols such as 104, 103, and Modbus.

PRS-7342 new energy intelligent integrated box transformer terminal has the function of ring network switch. Two sets of optical fiber interfaces can reliably access the optical fiber ring network. One Ethernet port realizes the upper connection, and two Ethernet network ports realize the lower Ethernet communication.

PRS-7342 new energy intelligent integrated box transformer terminal has complete data storage and upload functions. It includes no less than 256 event sequence records, 128 remote and local operation records, 128 device abnormality records and other information.

PRS-7342 new energy intelligent integrated box transformer terminal supports data centralization

and forwarding.

PRS-7342 new energy intelligent integrated box transformer terminal can expand the LCD display function to facilitate debugging and maintenance.

The PRS-7342 new energy intelligent integrated box transformer terminal can be used for centralized screen assembly or outdoor installation. Its inner and outer box structural design, rainproof, moisture-proof, dustproof, anti-corrosion, high-temperature isolation, anti-electromagnetic interference and other protective properties fully meet the needs of outdoor installation and operation.

1.4. Design specifications

The design of the device refers to specifications and timely tracks the latest versions of relevant industry and enterprise standards and specifications, including but not limited to:

- GB/T 19964 Technical Requirements for Connecting Photovoltaic Power Station to Power System
- GBT_50866 Design Code for Photovoltaic Power Station Connecting to Power System
- GBT_19963 Technical Specification for Connecting Wind Power Plant to Power System
- QGDW 392 Technical Regulations for Wind Farm Access to Power Grid
- Notice of State Grid Corporation of China on the issuance of 6 standards including *Information Exchange Specification for Dispatching of Wind Farm*
- Q/GDW 11198 Technical Specification for Grid-Related Protection of Distributed Resources
- Q/GDW 11120 Technical Specification for Protection and Security Automatic Equipment of Distribution Network with Distributed Resources
- Q/GDW 11199 General Specifications for Distributed Resources Protection and Security Automatic Equipment
- GB/T 191 Packaging - Pictorial Marking for Handling of Goods
- DL/T 1080 Application Integration at Electric Utilities-system Interfaces for Distribution Management
- DL/T 890 Energy Management System Application Program Interface
- IEC 61850 Substation Automation Standard
- DL5002 Code for Design of Dispatch Automation in District Power Grid
- DL/T550 Functional Specifications for Regional Power Grid Dispatching Automation
- DL516 Code for Operation and Administration of Power Dispatching Automation System
- DL5003 Specifications for the Design of Dispatch Automation in Electric Power Systems
- DL476 Power System Real-time Data Communication Application Layer Protocol

- GB/T 17626.1 Electromagnetic Compatibility - Testing and Measurement Techniques - Overview of Immunity Tests
- GB/T 17626.2 Electromagnetic Compatibility—Testing and Measurement Techniques—Electrostatic Discharge Immunity Test
- GB/T 17626.3 Electromagnetic Compatibility—Testing and Measurement Techniques—Part 3: Radiated, Radio-Frequency, Electromagnetic Field Immunity Test
- GB/T 17626.4 Electromagnetic Compatibility—Testing And Measurement Techniques—Surge Immunity Test
- GB/T 17626.5 Electromagnetic Compatibility—Testing and Measurement Techniques—Electrical Fast Transient/Burst immunity Test
- GB/T 17626.8 Electromagnetic Compatibility—Testing and Measurement Techniques—Power Frequency Magnetic Field Immunity Test
- GB/T 17626.10 Electromagnetic Compatibility—Testing and Measurement Techniques—Damped Oscillatory Magnetic Field Immunity Test
- GB/T 15153.1 Telecontrol Equipment and Systems—Part 2: Operating Conditions—Section 1: Power Supply and Electromagnetic Compatibility
- GB/T 15153.1 Electromagnetic Compatibility (EMC) - Testing And Measurement Techniques - Voltage Dips, Short Interruptions and Voltage Variations on d.c. Input Power Port Immunity Tests
- GB/T 11022 Common Specifications for High-Voltage Alternating-Current Switchgear and Controlgear Standards
- GB/T 14285 Technical Code for Relaying Protection and Security Automatic Equipment
- GB 4208 Degrees of Protection Provided By Enclosure(IP Code)
- GB/T 13729 Remote Terminal Unit Equipment
- GB/T5096 Electromechanical Components for Electronic Equipment—Basic Testing Procedures and Measuring Methods
- GB/T 19520 Electromechanical Components for Electronic Equipment—Basic Testing Procedures and Measuring Methods
- GB 7251.5 Low-Voltage Switchgear and Control Gear Assemblies—Part 5: Particular Requirements for Assemblies Intended to Be Installed Outdoors in Public Places—Cable Distribution Cabinets (CDCs) for Power Distribution in Networks
- DL/T637 Specification For Order of the Valve Regulated Sealed Lead-Acid Batteries
- DL/T 634.5-101: Subset of Standard Transmission Protocols for Telecontrol Equipment and Systems-Part 101

- DL/T 634.5-104: Subset of Standard Transmission Protocols for Telecontrol Equipment and Systems-Part 104
- DL/T 630 Technical Condition for RTU with AC Sampling
- GB/T 2423 Environmental Testing for Electric and Electronic Products
- GB/T 11287 Electrical Relays--Part 21:Vibration, Shock, Bump and Seismic Tests on Measuring Relays and Protection Equipment--Section One: Vibration Tests (Sinusoidal)
- GB/T 14537 Shock and Bump Tests on Measuring Relays and Protection Equipment
- IEC60297 Mechanical Structures for Electrical And Electronic Equipment

2. Technical parameters

2.1. Mechanical and environmental parameters

Normal operating temperature: $-40^{\circ}\text{C}\sim+70^{\circ}\text{C}$;

Maximum rate of change of ambient temperature: $1^{\circ}\text{C}/\text{min}$;

Relative humidity: $5\%\sim 100\%$;

Maximum absolute humidity: $35\text{g}/\text{m}^3$;

Atmospheric pressure: $70\text{kPa}\sim 106\text{kPa}$;

Altitude: $< 3000\text{m}$;

Chassis protection performance:

Part	Panel	Back panel	Side panel	Upper and lower bottom panels
Performance level	$\geq\text{IP40}$	$\geq\text{IP20}$	$\geq\text{IP30}$	$\geq\text{IP30}$

2.2. Rated electrical parameters

Frequency: 50Hz ;

Nominal value of voltage input: 800V and below line voltage, including $100\text{V}/220\text{V}/380\text{V}/690\text{V}/800\text{V}$, etc.;

Nominal value of current input: $5\text{A}/1\text{A}$;

DC power supply: 24V (power board model is SR16 81-A0)/ 220V (power board model is SR1681-C0);

AC power supply: 220V (power board model is SR1681-C0);

Power consumption:

AC voltage circuit: $<0.25\text{VA}/\text{phase}$;

AC current circuit: $<0.25\text{VA}/\text{phase}$;

Overload capacity:

AC voltage: 1.2 times rated voltage, continuous operation;

AC current: 1.2 times rated current, continuous operation;

10 times rated current, 10 seconds allowed.

20 times rated current, 1 second allowed.

2.3. Main technical indicators

2.3.1. AC sampling

Sampling accuracy of AC voltage and current: Level 0.5;

Sampling accuracy of DC voltage: Level 0.5;

Sampling accuracy of frequency: 0.01Hz;

Sampling accuracy of Active power, reactive power, power factor: Class 1.0;

The input range of fault current is 0.1~20In (In is the rated input current) linear range, and the total error of 20In fault current is not more than $\pm 1\%$.

2.3.2. Remote signaling input

Signal input mode: passive contact;

The input circuit adopts photoelectric isolation;

Contact voltage: DC24V;

SOE resolution: less than 2 milliseconds;

Remote signaling status change transmission time during an accident: less than 1 second;

Software anti-jitter time: 0-60000 milliseconds can be set.

2.3.3. Remote control output

Output mode: Relay normally open contact;

Contact capacity: 5A/AC250V, 10A/DC30V;

Remote control holding time: Each remote control contact can set the remote control pulse width separately.

2.3.4. Power supply

Main power supply: DC/AC 220V (power board model is SR1681-C0), allowable deviation -20% to +20%;

DC 24V (power board model is SR1681-A0), allowable deviation -20% to +20%;

Power consumption of the whole machine (full configuration of the whole floor) < 20VA.

2.3.5. Reliability

The mean time between failures is not less than 50,000 hours.

2.4. Electromagnetic compatibility

2.4.1. Fast transient pulse group interference

The standard for electrical fast transient pulse group interference is: GB/T17626 Electromagnetic Compatibility—Testing and Measurement Techniques;

Severity level: Level 4;

The device is in normal working condition, and all indicators meet the requirements in 2.3.

2.4.2. Surge interference

Surge interference is based on the standard: GB/T 17626 Electromagnetic Compatibility—Testing and Measurement Techniques;

Severity level: Level 4;

Test voltage: 4kV and 1.2/50 μ s waveform;

The device is in normal working condition, and all indicators meet the requirements in 2.3.

2.4.3. Electrostatic discharge interference

Electrostatic discharge interference is based on the standard: GB/T 17626 Electromagnetic Compatibility—Testing and Measurement Techniques;

Severity level: Level 4;

Test voltage: 8kV, contact discharge;

The device is in normal working condition, and all indicators meet the requirements in 2.3.

2.4.4. Power frequency magnetic field and damped magnetic field interference

Power frequency magnetic field interference is based on the standard: GB/T 17626 Electromagnetic Compatibility—Testing and Measurement Techniques;

Severity level: Level 4;

Test field strength: 100A/m;

The device is in normal working condition, and all indicators meet the requirements in 2.3.

2.4.5. High frequency interference

High frequency interference is based on the standard: GB/T17626 Electromagnetic

Compatibility—Testing and Measurement Techniques;

Severity level: Level 3;

Common mode 2.5kv, differential mode 1.25kv

The device is in normal working condition, and all indicators meet the requirements in 2.3.

2.4.6. Radiated electromagnetic field interference

Radiated electromagnetic field interference is based on the standard: GB/T17626 Electromagnetic Compatibility—Testing and Measurement Techniques;

Severity level: Level 4;

Electromagnetic field strength: 30V/m;

The device is in normal working condition, and all indicators meet the requirements in 2.3.

2.4.7. Sudden drop and interruption of power supply voltage sudden

Sudden drop and interruption of power supply voltage are based on the standard: GB/T15153.1 Telecontrol equipment and systems—Part 2: Operating conditions—Section 1: Power supply and electromagnetic compatibility;

Voltage sudden drop: ΔU is 100%;

Voltage interruption: 0.5s;

The device is in normal working condition, and all indicators meet the requirements in 2.3.

2.5. Insulation test

Insulation performance is based on the standard: GB/T 14598.3 Electrical Relays-Part 5: Insulation Coordination for Measuring Relays and Protection Equipment-Requirements and Tests

2.5.1. Insulation resistance

The insulation resistance between the input and output circuits of the device unit to the ground and between each circuit shall meet the following requirements:

Under normal test atmospheric conditions, the insulation resistance is as shown in the following table:

Rated insulation voltage U	Insulation resistance requirements
$U \leq 60$	$\geq 10M\Omega$ (using 250V megohmmeter)
$U > 60$	$\geq 10M\Omega$ (using 500V megohmmeter)
Note: For interface circuits directly connected to secondary equipment and external circuits, the insulation resistance requirement for $U > 60$ V shall be adopted.	

Under constant humidity and heat conditions with a temperature of $40\text{ }^{\circ}\text{C} \pm 2\text{ }^{\circ}\text{C}$ and a relative humidity of $(93 \pm 3)\%$, the insulation resistance is as shown in the following table:

Rated insulation voltage U	Insulation resistance requirements
$U \leq 60$	$\geq 5\text{M}\Omega$ (using 250V megohmmeter)
$U > 60$	$\geq 5\text{M}\Omega$ (using 500V megohmmeter)

Note: For interface circuits directly connected to secondary equipment and external circuits, the insulation resistance requirement for $U > 60\text{ V}$ shall be adopted.

2.5.2. Dielectric strength

The power supply of the device unit, AC input, output circuit and the normally open contacts of the output relay can withstand the AC withstand voltage test as shown in the following table, without breakdown and flashover.

Rated insulation voltage U	Effective value of test voltage
$U \leq 60$	500V
$60 < U \leq 125$	1000V
$125 < U \leq 250$	2000V

Note: For interface circuits directly connected to secondary equipment and external circuits, the insulation resistance requirement for $125 < U \leq 250$ shall be adopted.

2.5.3. Surge voltage

The power supply of the device unit, the input and output circuits can withstand the short-time impulse voltage test with the test voltage as shown in the following table for the ground and between each circuit.

Rated insulation voltage U	Effective value of test voltage
$U \leq 60$	1kV
$U > 60$	5kV

2.6. Mechanical performance

a) Vibration

Vibration endurance: Complies with the requirements of GB/T 15153.2 - 2000, with a severity level of Bm.

b) Shock

Shock endurance: Complies with the requirements of GB/T 15153.2 - 2000, with a severity level of Bm.

3. Device functions and principles

Depending on the device model, the specific function configuration is referred to the following table:

Table 3-0-1 Device Function Configuration Table

Device function	Device model	PRS-7342 New energy intelligent integrated box transformer device
Telemetry, remote signaling, remote control		<input checked="" type="checkbox"/>
Parameter setting		<input checked="" type="checkbox"/>
Device self-test		<input checked="" type="checkbox"/>
Time synchronization		<input checked="" type="checkbox"/>
Data storage		<input checked="" type="checkbox"/>
Communication management		<input checked="" type="checkbox"/>
Fiber optic ring network switching		<input checked="" type="checkbox"/>
Data forwarding		<input checked="" type="checkbox"/>
Debugging		<input checked="" type="checkbox"/>
Relay protection		<input checked="" type="checkbox"/>

3.1. Telemetry, remote signaling, remote control

3.1.1. Telemetry function

After the voltage/current on the secondary side is converted into a corresponding weak voltage signal by PT/CT, telemetered quantities enter the 16-bit A/D conversion chip for collection. The on-site standard secondary voltage (line voltage of 800V and below, including 100V/220V/380V/690V/800V, etc.) and current (5A or 1A) are isolated and converted into weak signals by high-precision small PT and CT, and sent to the DSP processing module for calculation and processing through the analog-to-digital converter (A/D).

Collect analog quantities such as U_a , U_b , U_c , I_a , I_b , and I_c .

Calculated telemetered quantities:

- Total and three-phase active power;
- Total and three-phase reactive power;
- Total power factor;
- Frequency;
- Current and voltage phase;
- Harmonics of current and voltage;
- Zero-sequence voltage ($3U_0$) and zero-sequence current ($3I_0$), etc.

3.1.2. Remote signaling function

The remote signal input signal is sent to the remote signal acquisition module for processing after passing through the photoelectric isolator in the form of an empty contact. Through hardware filtering and anti-jitter of remote signaling, the separation and combination state of the remote signaling input signal is obtained.

Through the combined remote signaling configuration of the device maintenance software, various combined remote signaling results after logical operation can also be obtained.

The remote signal anti-jitter time can be set to ensure that a remote signaling status change occurs only when a stable remote signaling action takes place, reducing false remote signaling alarms.

The following are common remote signaling quantities:

- Collect the closing and opening state quantity information of switches and grounding switches;
- Overvoltage, grounding and other fault remote signaling;
- Collect the state quantity of inverters, meters and other equipment;
- Collect the opening and closing state information of cabinet doors;
- Collect the energy storage state of switches;
- The remote signaling input quantity can be defined according to the specific requirements of users.

3.1.3. Remote control function

The device can accept remote control execution or cancellation commands to complete the opening and closing operations of switches. Each remote control contact can set the remote control pulse width separately.

3.2. Parameter setting function

The device parameters can be set and modified through the human - machine interface or maintenance software of the device. These parameters include system parameters, telemetry parameters, remote signaling parameters, remote control parameters, communication parameters, protection setting values and parameters, etc.

3.3. Device self-test function

When the device detects a hardware fault, it sends a locking signal and locks the device output relay at the same time. For example, in cases such as incorrect device parameters, RAM failure, ROM failure, power supply failure, device abnormality, etc.

The device has self-diagnosis and self-recovery functions. It can self-diagnose various functional boards and important chips, send alarm information when a fault occurs, automatically reset when an abnormality occurs, and automatically resume normal operation.

3.4. Time synchronization function

PRS-7342 new energy intelligent integrated box transformer terminal has a time synchronization function. It supports multiple time calibration methods such as master station, SNTP and GPS, and the device time can also be set through the human-machine interface or maintenance software.

After the device is powered off, the clock can continue to count normally. Within 24 hours after power - off, the clock error does not exceed 2 seconds.

3.5. Data storage function

The PRS-7342 new energy intelligent integrated box transformer terminal has a historical data storage function, including event sequence records (SOE), remote signaling status change records (COS), remote and local operation records, device abnormal records, telemetry historical data records, fault wave recording records and other information.

Mainly include:

- Alarm records, including CT disconnection, PT disconnection and other alarms;
- Action records, including directional overcurrent, overvoltage and other protection;
- Remote control records, recording the time and status of remote control execution;
- Self-test records, recording the self-test status of each module during the operation of the device;
- Restart records, when the device is restarted or reset, a restart record will be generated;
- Abnormal records, recording abnormal conditions of the device;
- Telemetry records, recording telemetry information;
- SOE records, recording the time and status of SOE displacement;
- Fault wave recording, recording the sampled waveform when the protection action is in action, including AC quantity, input quantity and output quantity information;

All records can be viewed through the human-machine interface or maintenance software. After power failure or communication interruption, data can be stored for a long time, and historical data can be supplemented and uploaded.

3.6. Communication function

The communication ports of the PRS-7342 new energy intelligent integrated box transformer

terminal include Ethernet port and serial communication port:

- The device is equipped with 3 Ethernet ports as standard, one of which is a debugging port, which can be expanded as needed to support 10/100BASE-T adaptive Ethernet communication;
- The device is equipped with 6 serial communication ports as standard, and the communication board can be expanded as needed to support RS-485/RS-232 communication.

The PRS-7342 new energy intelligent integrated box transformer terminal supports multiple types of communication methods:

- It supports Ethernet or EPON communication based on optical fiber;
- It supports wireless GPRS/CDMA communication;
- It supports power carrier communication.

The PRS-7342 new energy intelligent integrated box transformer terminal supports flexible configuration of multiple communication protocols on communication ports:

- Multiple communication ports realize communication with multiple monitoring systems and other intelligent devices;
- It supports multiple communication protocols such as IEC60870-5-104, Modbus, GOOSE, etc.

3.7. Fiber optic ring network switching

PRS-7342 new energy intelligent integrated box transformer terminal has the function of optical fiber ring network switching. Two sets of optical fiber interfaces can reliably form an optical fiber ring network, and one Ethernet port provides information exchange function.

3.8. Data forwarding function

PRS-7342 new energy intelligent integrated box transformer terminal has data forwarding function. It can be connected to various monitoring systems at the upper level and various electric meters and other devices and equipment without remote transmission function at the lower level.

3.9. Debugging function

- Remote maintenance can be performed through Ethernet;
- It can be connected to a portable computer through the human-machine interface or through the Ethernet port or serial port for local debugging;
- The device panel is equipped with various operating indicators, such as power indicator, operating indicator, fault indicator, etc., for easy debugging;

Set the Ethernet port or serial port to maintenance protocol, and the following main debugging and maintenance can be performed through the supporting maintenance software:

Parameter setting: The device parameters can be set and modified, including system parameters, telemetry parameters, remote signaling parameters, remote control parameters, protection setting value and time limit, etc.

Communication configuration: Communication ports can be configured, such as communication protocols, baud rates, parity checks, etc. The forwarding table and device groups (for monitoring) can also be configured to realize communication and data forwarding functions.

Operation monitoring: The real-time data of the device can be monitored, the device clock can be viewed, time synchronization can be carried out, and system settings can be adjusted.

3.10. Function and principle of relay protection

The new energy intelligent integrated box transformer terminal has complete protection and alarm functions, and has three-stage directional overcurrent, two-stage negative sequence overcurrent, three-stage zero-sequence overcurrent, overvoltage, low-voltage and other protection elements.

3.10.1. Three-stage directional overcurrent protection

The device is equipped with three-stage directional overcurrent protection blocked by low-voltage. The three stages of protection are independently configured, but have the same protection logic.

Directional element description:

The device stipulates that the flow from the busbar to the line is in the positive direction, and the directional element adopts 90° wiring ($I_a \rightarrow U_{bc}/I_b \rightarrow U_{ca}/I_c \rightarrow U_{ab}$). The action equation for the positive direction is as follows (the values in parentheses represent the maximum error range):

$$-85^\circ (\pm 5^\circ) < \arg \frac{\dot{I}_r e^{-j45^\circ}}{\dot{U}_r} < 85^\circ (\pm 5^\circ) \quad (3-11-1)$$

Where: \dot{I}_r and \dot{U}_r respectively represent the corresponding current and voltage in the 90° wiring method.

The device uses memory voltage to eliminate the dead zone of the directional element when the three-phase short circuit occurs in the near area, and the dead zone line voltage threshold is 9V.

The compound pressure locking component is locked by PT disconnection. When the branch PT is disconnected, whether to block the compound voltage component can be selected via the setting value of "PT disconnection blocking protection".

When "PT disconnection blocking protection" is enabled, the current protection will be directly disabled when "PT disconnection alarm" occurs;

The specific logic diagram is shown in the figure below:

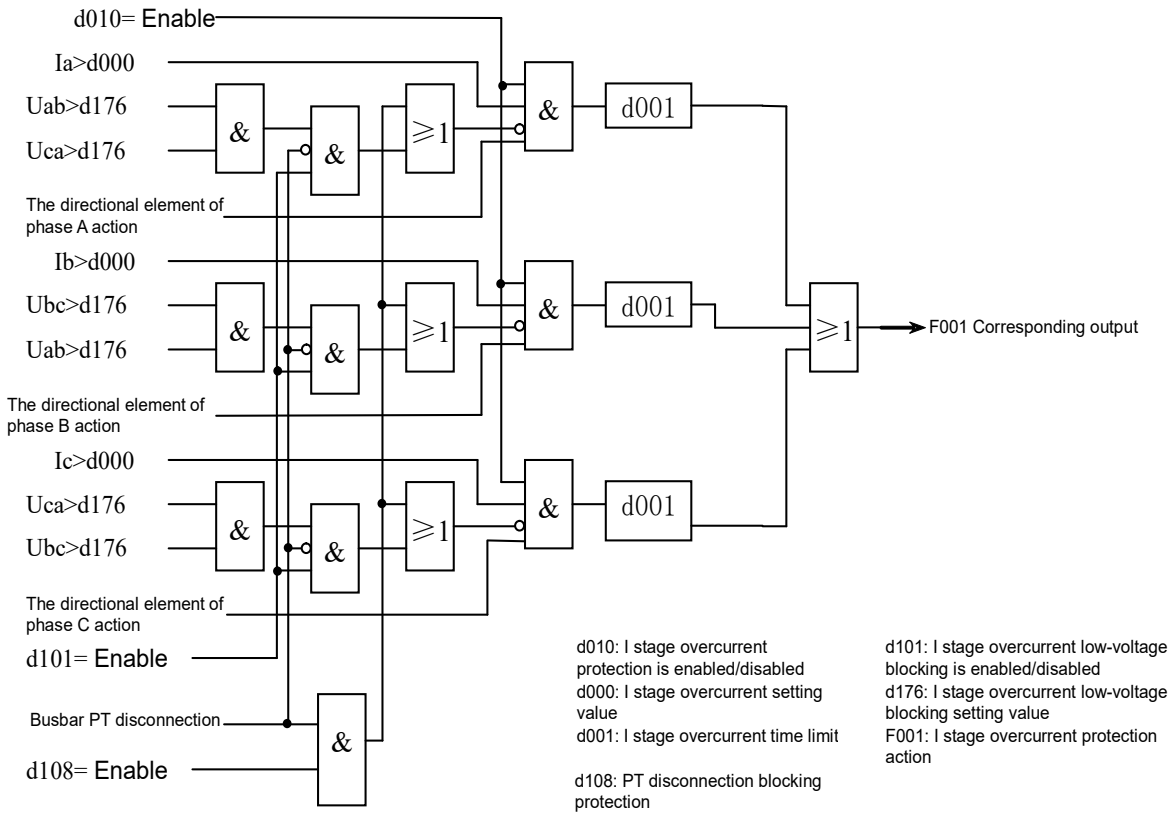

Figure 3-10-1 Logic Diagram of Phase Overcurrent Protection

3.10.2. Two-stage negative sequence overcurrent protection

The device is equipped with two independent negative sequence current protections. The two protections can be independent and have the same logic principle.

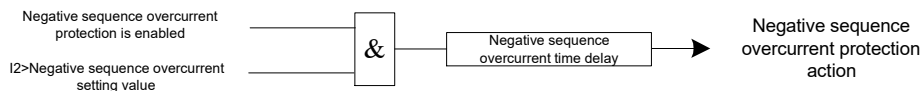

Figure 3-10-2 Logic Diagram of Negative Sequence Overcurrent Protection

3.10.3. Three-stage zero-sequence directional overcurrent protection

Zero-sequence overcurrent protection is a protection for ground faults. Each line is equipped with its own protection enable/disable function, time limit, and overcurrent setting value. Zero-sequence current is calculated by I_a , I_b , and I_c . The three-stage zero-sequence overcurrent protection has the same principle and can be enabled or disabled separately through control words.

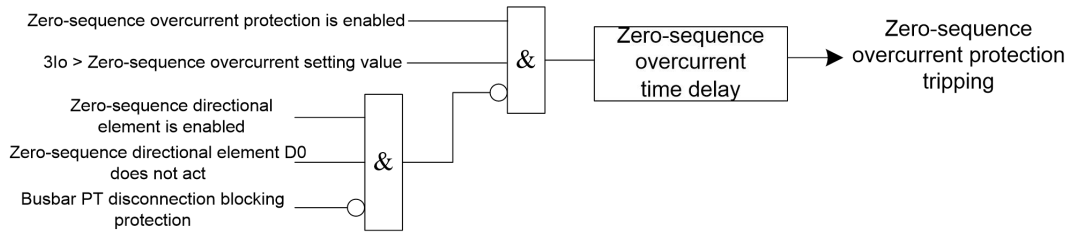

Figure 3-11-3 Logic Diagram of Zero-sequence Directional Overcurrent Protection for Neutral Point Ungrounded System

Use zero-sequence directional overcurrent protection, in which the directional element can be enabled and disabled.

- 1) When the zero-sequence directional element is enabled, if the PT disconnection blocking protection occurs, the directional element will be automatically disabled.
- 2) Since the zero-sequence current transformer is of the bushing type, a polarity test should be performed after installation.
- 3) The zero-sequence directional element is judged only when the zero-sequence voltage is greater than 8V and the zero-sequence current is greater than 0.01In. In other cases, the directional element is blocked (i.e., it does not act at all).

The action equation of the zero-sequence overcurrent protection directional element D0 is (the maximum error range is in brackets)

$$185^\circ(\pm 5^\circ) < \arg \frac{3\dot{I}_0}{3\dot{U}_0} < 355^\circ(\pm 5^\circ) \tag{3-11-2}$$

3.10.4. Low-voltage protection

The low-voltage protection action must go through the judgment of once having voltage (the three-phase line voltage is greater than 30V and lasts for 1s, and the device judges that the system once had voltage). After the low-voltage disconnection element returns to action, it also needs to go through the judgment of once having voltage before it can act again. Low-voltage protection is blocked by HWJ and PT disconnection.

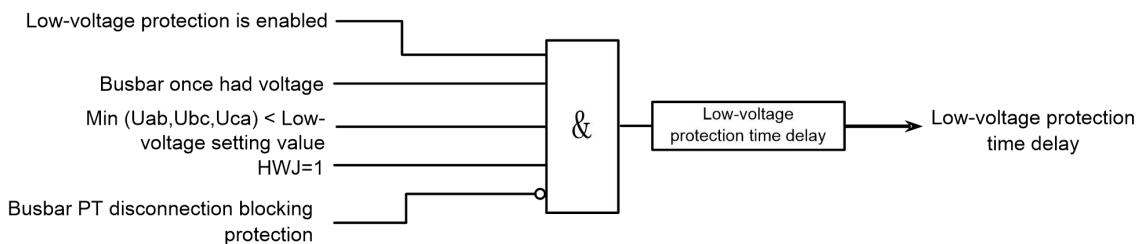

Figure 3-10-4 Logic Diagram of Low-voltage Protection

3.10.5. Overvoltage protection

When any line voltage is greater than the overvoltage setting value, the overvoltage protection acts.

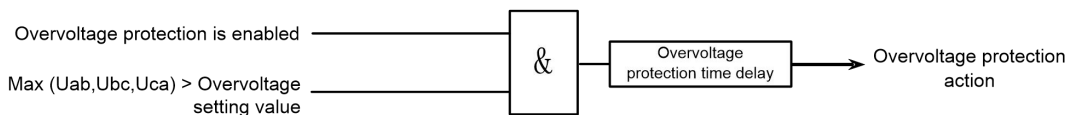

Figure 3-10-5 Logic Diagram of Overvoltage Protection

3.10.6. Zero-sequence overvoltage protection

The principle of zero sequence overvoltage is similar to that of overvoltage protection. The zero-sequence voltage is the unbalanced voltage calculated from the three-phase voltage.

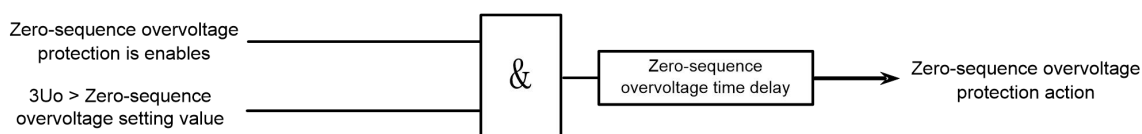

Figure 3-10-6 Logic Diagram of Zero-sequence Overvoltage Protection

3.10.7. Non electricity protection

The device is equipped with 6 non electricity protection inputs. The non electricity protection can be selected to enable or disable the tripping function,, and the non electricity protection is blocked by HWJ.

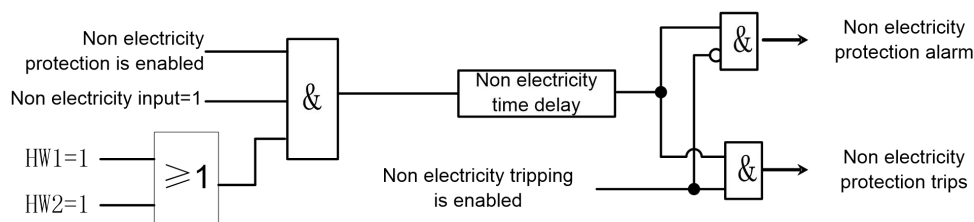

Figure 3-10-7 Logic Diagram of Non Electricity Protection

3.10.8. Longitudinal differential protection

Longitudinal differential protection includes longitudinal differential quick break protection and ratio differential protection. The protection is designed according to the differential characteristics of the system. The differential protection characteristics are shown in the figure.

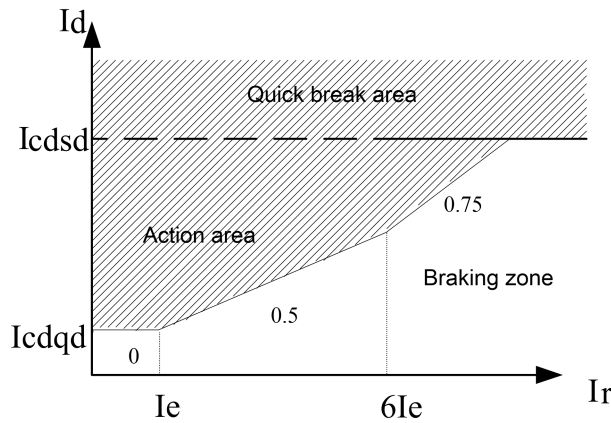

Figure 3-10-7 Action Characteristics of Longitudinal Differential Protection

I_d is the differential current, I_r is the braking current, I_e is the secondary rated current on the high-voltage side of the transformer; I_{cdqd} is the “ratio differential protection starting current setting value”, I_{cdsd} is the “longitudinal differential quick break current setting value”. For the calculation of differential current and braking current in differential protection, see Appendix C.

3.10.8.1. Longitudinal differential quick break protection

When the differential current of any phase is greater than the setting value I_{cdsd} (longitudinal differential quick break current setting value), the protection will instantly cut off the transformer.

The protection action logic is shown in the figure. I_{cdsd} The setting value is determined to avoid the maximum inrush current, and the return coefficient is taken as 0.98. As a protection for severe faults within the differential protection range, CT saturation and CT disconnection will not Block the protection.

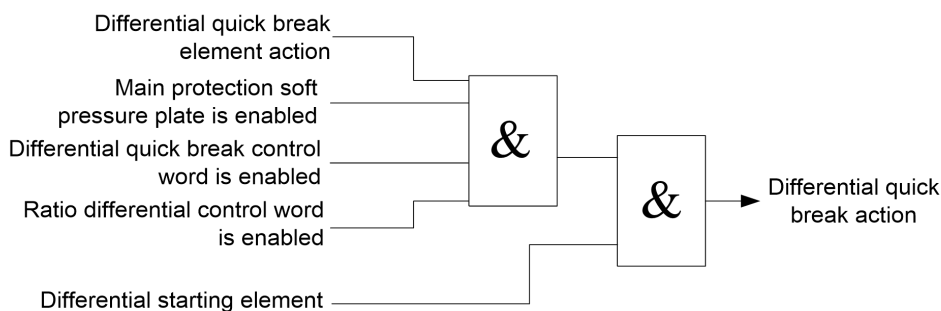

Figure 3-10-8 Logic Diagram of Longitudinal Differential Quick Break Protection

3.10.8.2. Ratio differential protection

The action logic of ratio differential protection is shown in the figure. The action characteristic of differential protection is realized by three-fold line method. The action equation is as follows:

$$\begin{cases} I_d > I_{cdqd} & , I_r \leq I_e \\ I_d > 0.5 * (I_r - I_e) + I_{cdqd} & , I_e < I_r \leq 6I_e \\ I_d > 0.75 * (I_r - 6I_e) + 0.5 * (6I_e - I_e) + I_{cdqd} & , I_r > 6I_e \end{cases} \quad (3-10-3)$$

Where: I_d is the differential current, $I_r = \left| \sum_{i=1}^n \dot{I}_i \right|$, $I_e = \frac{1}{2} \sum_{i=1}^n |\dot{I}_i|$ ($\dot{I}_1, \dots, \dot{I}_n$ are the currents on each side of the differential, respectively). The ratio differential starting current setting value I_{cdqd} is used to avoid the unbalanced current during the normal operation of the transformer, and the return coefficient is 0.98.

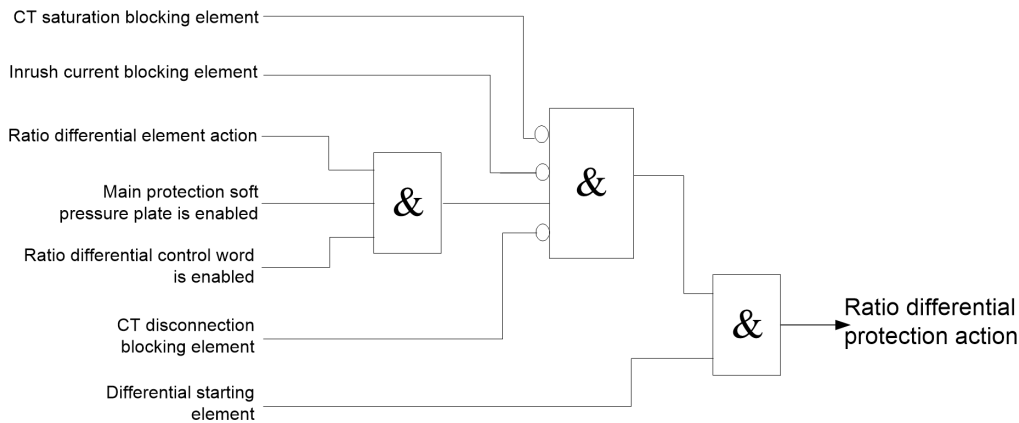

Figure 3-10-9 Logic Diagram of Ratio Differential Protection

3.10.8.3. Inrush current blocking principle

The inrush current blocking method of this device adopts a comprehensive criterion combining the second harmonic braking and waveform recognition principles.

Second harmonic braking principle

The ratio of the second harmonic to the fundamental wave in the three-phase differential current is used as the criterion for the inrush current blocking, and its action equation is as follows:

$$I_{2nd} > K_{2xb} \cdot I_{1st} \quad (3-10-4)$$

Where: I_{2nd} is the second harmonic in each phase differential current, I_{1st} is the fundamental wave of the corresponding phase differential current, K_{2xb} is the second harmonic braking coefficient, which is calculated internally and is taken as 0.15 internally.

For longitudinal differential protection, this device adopts our company's original second harmonic

composite logic braking principle, which has been confirmed by a large amount of operating experience. Specifications are as follows:

- 1) For the Y / Δ wiring transformer, the differential current reflects the phase difference between the two-phase currents on the Y-connected wiring side. When the transformer is energized on the Y-connected wiring side, the stronger inrush characteristics (second harmonic content or interruption angle) in the single-phase current may weaken the inrush characteristics in the differential current after the two-phase current is subtracted. In this case, the traditional method of extracting the second harmonic component from the differential current to achieve braking may fail. The CT on the Y side of transformer in this device is also connected in a Y-shape, so when the second harmonic of the differential current fails to brake, the second harmonic in the original two phase currents can be further used for braking, which greatly improves the reliability of the inrush braking.
- 2) The conventional second harmonic inrush braking principle is to block all three phase ratio differential protections when any phase differential current inrush braking is performed, which is called “OR” braking logic. If the “OR” logic is used alone for braking, the differential protection may act slowly when energized on the faulty transformer. This device adopts the inrush current composite braking logic according to the reflection of inrush current and fault current in the three-phase differential current: when the transformer is fault-free, the “OR” logic braking method is used to reliably avoid the inrush current, and when it is energized on the faulty transformer, it automatically switches to the phase-splitting braking method, ensuring that the ratio differential protection can still act quickly and sensitively when it is energized on the faulty transformer.

Waveform recognition principle

During a fault, the differential current is basically a power frequency sine wave, while during the an inrush current, there are a large number of harmonic components, and the waveform is distorted, discontinuous and asymmetric. By using the algorithm to identify this distortion, the inrush current can be identified.

During a fault, the following expression is established:

$$S_+ \leq K_b * S_- \quad (3-10-5)$$

Where: S_+ is the half-wave integral value of $\left| I'_i + I'_{i+\frac{T}{2}} \right|$, S_- is the half-wave integral value of $\left| I'_i - I'_{i+\frac{T}{2}} \right|$; k_b is the waveform asymmetry coefficient. I'_i is the value of a certain point in the first half wave of the differential current derivative, $I'_{i+\frac{T}{2}}$ is the value of the corresponding point in the second half wave of the differential current derivative. k_b is generally set between 0.1 and 0.2.

3.10.8.4. CT disconnection block differential protection

This criterion is the differential protection CT disconnection criterion.

First, the possibility of multiple CT disconnection and faults occurring simultaneously is not considered. Under this premise, the following characteristics can be used to distinguish whether it is a CT disconnection or a fault. If it is a CT disconnection, the disconnection phase can be specifically identified.

Single-phase or two-phase disconnection:

Table 3-10-1 CT Disconnection/Fault Criteria

	CT disconnection	Fault
Current change situation	Current mutation only on the disconnection side	Current mutation on multiple sides
Current change trend	From large to small	From small to large
Current amplitude situation	$\leq 0.08I_N$	$\geq I_N$

The standard for current mutation is whether the mutation is greater than 5-10% I_N (I_N is the rated current of the CT secondary side, fixed in the device, $I_N=1A$).

After the CT is disconnected, an alarm signal is issued. Whether to instantaneously block the relevant differential protection can be set through control. The condition for CT disconnection return is that there is no zero-sequence current and negative-sequence current on the disconnected side, and there is no differential current in the relevant differential.

The CT disconnection block ratio differential follows the following principles:

(1) When the CT is disconnected or short-circuited, the ratio differential protection is blocked (when the differential current is less than $1.2I_e$, the differential protection is blocked, and when it is greater than $1.2I_e$, the differential protection is not blocked. Here, I_e refers to the secondary rated current on the high-voltage side of the transformer);

(2) The CT disconnection blocking function is mainly to prevent the differential protection from malfunctioning due to the CT disconnection. It follows the following principles: First, it does not consider the simultaneous occurrence of CT disconnection and faults on multiple sides; second, the differential protection is allowed to trip when the fault and CT disconnection occur at the same time; third, the CT disconnection occurs first and then the fault to block the related protection; fourth, the CT disconnection protection should trip at the outlet when the fault occurs first and then the CT disconnection protection.

3.10.8.5. CT saturation blocking

In order to prevent the differential protection from malfunctioning due to CT saturation when there is a fault outside the zone, the device has a CT saturation detection element to determine whether the CT is saturated and determine whether to block the related differential protection.

When there is a fault inside the zone, there will be:

$$\sum_{i=1}^n |\Delta \dot{I}_i| = \left| \sum_{i=1}^n \Delta \dot{I}_i \right| \tag{3-10-6}$$

Where: n is the number of sides shared by the transformer. The left side is equivalent to the braking current, and the right side is equivalent to the differential current. The above formula does not hold when there is an out-of-zone fault or an out-of-zone fault and the CT is saturated. In fact, if the differential current is caused by CT saturation, the differential current is generated some time after the CT is saturated. Therefore, the device uses the timing consistency of the braking current and the differential current to determine whether it is saturated. If it is saturated, the ratio differential braking coefficient is automatically raised to ensure the reliability of the differential. At the same time, it can ensure rapid action when the out-of-zone fault is saturated and converted to an in-zone fault.

3.10.9. Busbar PT disconnection alarm

The busbar PT disconnection check uses the line voltage drop and negative-sequence voltage rise criteria, with a delay of 10s alarm. The negative-sequence voltage is calculated by the software from the three-phase voltage. If the control word $d108=enabled$, the current blocking element is added to the busbar PT disconnection alarm criterion, that is, when the three-phase currents are all less than $0.04I_n$, the busbar PT disconnection alarm element is disabled.

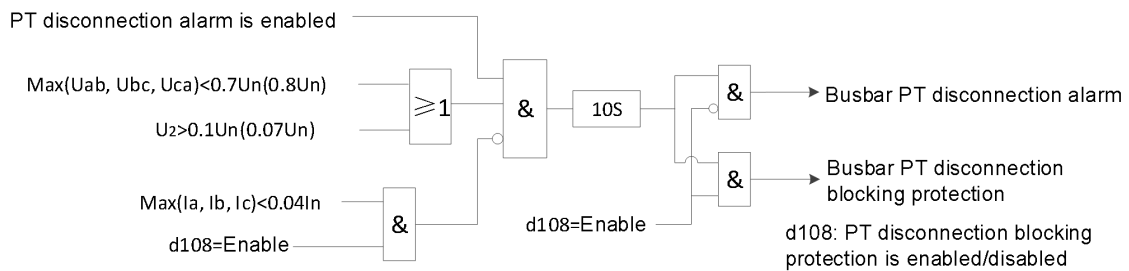

Figure 3-10-8 Logic Diagram of Busbar PT Disconnection Alarm

3.10.10. CT disconnection alarm

CT disconnection alarm uses zero-sequence current and zero-sequence voltage to judge, and the alarm is delayed for 10S.

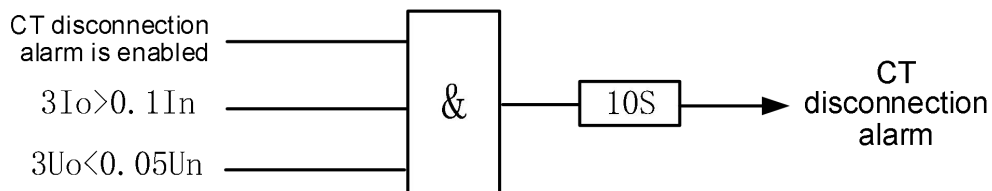

Figure 3-10-9 Logic Diagram of CT Disconnection Alarm

3.10.11. Busbar grounding alarm

The busbar grounding fault is judged according to the busbar unbalanced voltage. The unbalanced voltage is calculated by software. The bus grounding unbalanced voltage is fixed at $0.18U_n$, and the delay is 10S.

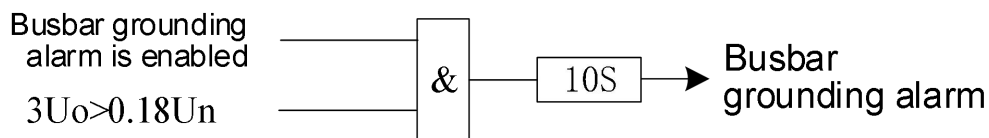

Figure 3-10-10 Logic Diagram of Busbar Grounding Alarm

3.10.12. TWJ abnormal alarm

If the switch jumps and there is current in the line, it is delayed for 10S to judge that TWJ is abnormal.

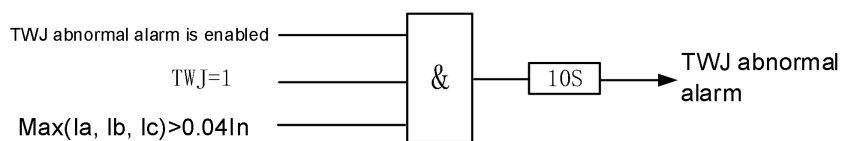

Figure 3-10-11 Logic Diagram of TWJ Abnormal Alarm

3.10.13. Switch position abnormal alarm

If the TWJ and HWJ input simultaneously or there is no input simultaneously, a switch position abnormal alarm is sent after a delay of 10s.

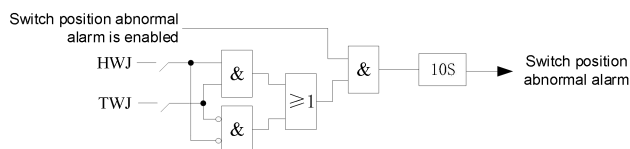

Figure 3-10-12 Logic Diagram of Switch Position Abnormal Alarm

3.10.14. Frequency abnormal alarm

When the frequency is lower than 49.5HZ, the "frequency abnormal alarm" is issued after a delay of 10S.

4. Device setting value

The setting value types are divided into: enable/disable type (or switch type) and numerical type. For enable/disable type setting value, "1" means enabled and "0" means disabled. For numerical type setting value, it is set bit by bit and can be set to any value within the setting range.

4.1. Device setting value

4.1.1. List of Setting values

This device can be connected to two branch lines of the box-type transformer. When only one branch is connected, only the setting value of the corresponding branch needs to be enabled.

Table 4-2-1 List of Setting values

Protection element	Name of setting value	Setting range and step size	Factory setting value
TV parameter	L1_PT primary rated value (line)	0.01-220.00kV, 0.01kV	10.00kV
	L1_PT secondary rated value (line)	57.74-2000V, 0.01V	100V
	L2_PT primary rated value (line)	0.01-220.00kV, 0.01kV	1.00
	L2_PT secondary rated value (line)	57.74-2000V, 0.01V	100V
	L1_PT number of phases connected (phase)	1-3, 1	3
	L2_PT number of phases connected (phase)	1-3, 1	3
TA parameter	L1 rated CT primary value	1-9999A, 1A	1000A
	L1 rated CT secondary value	1/5A, 1A	1A
	L2 rated CT primary value	1-9999A, 1A	1000A
	L2 rated CT secondary value	1/5A, 1A	1A
The shortest time for the protection tripping outlet	The broadening time for the protection tripping outlet	0.001-100.000s, 0.001s	5.000s
	The broadening time for the protection tripping outlet	0.001-100.000s, 0.001s	5.000s
Power voltage setting	Power voltage of Line 01 (voltage group)	1-2, 1	1
	Power voltage of Line 02 (voltage group)	1-2, 1	2
Automatic control	Enable/disable of delayed reset	Disable/enable	Disable
	Delayed reset time limit	1-864000s, 1s	86400s
Telemetry record	Recording cycle of electric energy measurement	0-2880min	0min
Phase overcurrent protection	Enable/disable of Line 01 Stage I overcurrent protection	Disable/enable	Disable
	Enable/disable of low-voltage blocking for Line 01 Stage I overcurrent protection	Disable/enable	Disable
	Enable/disable of directional element for Line 01 Stage I overcurrent protection	Disable/enable	Disable
	Setting value of Line 01 Stage I overcurrent protection	0.01-100.00, 0.01A	100.00A

Protection element	Name of setting value	Setting range and step size	Factory setting value
	Time limit of Line 01 Stage I overcurrent protection	0-100.000s, 0.001s	100.00s
	Low-voltage blocking setting value for Line 01 Stage I overcurrent protection	0-2000V, 0.01V	200V
	Enable/disable of Line 01 Stage II over current protection	Disable/enable	Disable
	Enable/disable of low-voltage blocking for Line 01 Stage II overcurrent protection	Disable/enable	Disable
	Enable/disable of directional element for Line 01 Stage II overcurrent protection	Disable/enable	Disable
	Setting value of Line 01 Stage II overcurrent protection	0.01-100.00, 0.01A	100.00A
	Time limit of Line 01 Stage II overcurrent protection	0-100.000s, 0.001s	100.00s
	Low-voltage blocking setting value for Line 01 Stage II overcurrent protection	0-2000V, 0.01V	200V
	Enable/disable of Line 01 Stage III overcurrent protection	Disable/enable	Disable
	Enable/disable of low-voltage blocking for Line 01 Stage III overcurrent protection	Disable/enable	Disable
	Enable/disable of directional element for Line 01 Stage III overcurrent protection	Disable/enable	Disable
	Setting value of Line 01 Stage III overcurrent protection	0.01-100.00, 0.01A	100.00A
	Time limit of Line 01 Stage III overcurrent protection	0-100.000s, 0.001s	100.00s
	Low-voltage blocking setting value for Line 01 Stage III overcurrent protection	0-2000V, 0.01V	200V
	Enable/disable of Line 02 Stage I overcurrent protection	Disable/enable	Disable
	Enable/disable of low-voltage blocking for Line 02 Stage I overcurrent protection	Disable/enable	Disable
	Enable/disable of directional element for Line 02 Stage I overcurrent protection	Disable/enable	Disable
	Setting value of Line 02 Stage I overcurrent protection	0.01-100.00, 0.01A	100.00A
	Time limit of Line 02 Stage I overcurrent protection	0-100.000s, 0.001s	100.00s
	Low-voltage blocking setting value for Line 02 Stage I overcurrent protection	0-2000V, 0.01V	200V
	Enable/disable of Line 02 Stage II over current protection	Disable/enable	Disable
	Enable/disable of low-voltage blocking for Line 02 Stage II overcurrent protection	Disable/enable	Disable
	Enable/disable of directional element for Line 02 Stage II overcurrent protection	Disable/enable	Disable
	Setting value of Line 02 Stage II overcurrent protection	0.01-100.00, 0.01A	100.00A
	Time limit of Line 02 Stage II overcurrent protection	0-100.000s, 0.001s	100.00s
	Low-voltage blocking setting value for Line 02 Stage II overcurrent protection	0-2000V, 0.01V	200V

Protection element	Name of setting value	Setting range and step size	Factory setting value
	Enable/disable of Line 02 Stage III overcurrent protection	Disable/enable	Disable
	Enable/disable of low-voltage blocking for Line 02 Stage III overcurrent protection	Disable/enable	Disable
	Enable/disable of directional element for Line 02 Stage III overcurrent protection	Disable/enable	Disable
	Setting value of Line 02 Stage III overcurrent protection	0.01-100.00, 0.01A	100.00A
	Time limit of Line 02 Stage III overcurrent protection	0-100.000s, 0.001s	100.00s
	Low-voltage blocking setting value for Line 02 Stage III overcurrent protection	0-2000V, 0.01V	200V
Negative-sequence current protection	Enable/disable of Line 01 Section I negative-sequence overcurrent protection	Disable/enable	Disable
	Setting value of Line 01 Section I negative-sequence overcurrent	0.01-100.00, 0.01A	100.00A
	Time limit of Line 01 Section I negative-sequence overcurrent	0-100.000s, 0.001s	100.000s
	Enable/disable of Line 01 Section II negative-sequence overcurrent protection	Disable/enable	Disable
	Setting value of Line 01 Section II negative-sequence overcurrent	0.01-100.00, 0.01A	100.00A
	Time limit of Line 01 Section II negative-sequence overcurrent	0-100.000s, 0.001s	100.000s
	Enable/disable of Line 02 Section I negative-sequence overcurrent protection	Disable/enable	Disable
	Setting value of Line 02 Section I negative-sequence overcurrent	0.01-100.00, 0.01A	100.00A
	Time limit of Line 02 Section I negative-sequence overcurrent	0-100.000s, 0.001s	100.000s
	Enable/disable of Line 02 Section II negative-sequence overcurrent protection	Disable/enable	Disable
	Setting value of Line 02 Section II negative-sequence overcurrent	0.01-100.00, 0.01A	100.00A
	Time limit of Line 02 Section II negative-sequence overcurrent	0-100.000s, 0.001s	100.000s
Zero sequence overcurrent protection	Enable/disable of Line 01 Section I zero-sequence overcurrent protection	Disable/enable	Disable
	Enable/disable of Line 01 Section I zero-sequence overcurrent direction	Disable/enable	Disable
	Setting value of Line 01 Section I zero-sequence overcurrent	0.01-100.00, 0.01A	100.00A
	Time limit of Line 01 Section I zero-sequence overcurrent	0-100.000s, 0.001s	100.000s
	Enable/disable of Line 01 Section II zero-sequence overcurrent protection	Disable/enable	Disable
	Enable/disable of Line 01 Section II zero-sequence overcurrent direction	Disable/enable	Disable
	Setting value of Line 01 Section II zero-sequence overcurrent	0.01-100.00, 0.01A	100.00A
	Time limit of Line 01 Section II zero-sequence overcurrent	0-100.000s, 0.001s	100.000s
	Enable/disable of Line 01 Section III zero-sequence overcurrent protection	Disable/enable	Disable
	Enable/disable of Line 01 Section III zero-sequence overcurrent direction	Disable/enable	Disable

Protection element	Name of setting value	Setting range and step size	Factory setting value
	Setting value of Line 01 Section III zero-sequence overcurrent	0.01-100.00, 0.01A	100.00A
	Time limit of Line 01 Section III zero-sequence overcurrent	0-100.000s, 0.001s	100.000s
	Enable/disable of Line 02 Section I zero-sequence overcurrent protection	Disable/enable	Disable
	Enable/disable of Line 02 Section I zero-sequence overcurrent direction	Disable/enable	Disable
	Setting value of Line 02 Section I zero-sequence overcurrent	0.01-100.00, 0.01A	100.00A
	Time limit of Line 02 Section I zero-sequence overcurrent	0-100.000s, 0.001s	100.000s
	Enable/disable of Line 02 Section II zero-sequence overcurrent protection	Disable/enable	Disable
	Enable/disable of Line 02 Section II zero-sequence overcurrent direction	Disable/enable	Disable
	Setting value of Line 02 Section II zero-sequence overcurrent	0.01-100.00, 0.01A	100.00A
	Time limit of Line 02 Section II zero-sequence overcurrent	0-100.000s, 0.001s	100.000s
	Enable/disable of Line 02 Section III zero-sequence overcurrent protection	Disable/enable	Disable
	Enable/disable of Line 02 Section III zero-sequence overcurrent direction	Disable/enable	Disable
	Setting value of Line 02 Section III zero-sequence overcurrent	0.01-100.00, 0.01A	100.00A
	Time limit of Line 02 Section III zero-sequence overcurrent	0-100.000s, 0.001s	100.000s
Low-voltage protection	Enable/disable of Line 01 low-voltage protection	Disable/enable	Disable
	Setting value of Line 01 low-voltage protection	0.01-2000V, 0.01V	500V
	Time limit of Line 01 low-voltage protection	0-100.000s, 0.001s	100.000s
	Enable/disable of Line 02 low-voltage protection	Disable/enable	Disable
	Setting value of Line 02 low-voltage protection	0.01-2000V, 0.01V	500V
	Time limit of Line 02 low-voltage protection	0-100.000s, 0.001s	100.000s
Overvoltage protection	Enable/disable of Line 01 overvoltage protection	Disable/enable	Disable
	Setting value of Line 01 overvoltage protection	0.01-2000V, 0.01V	500V
	Time limit of Line 01 overvoltage protection	0-100.000s, 0.001s	100.000s
	Enable/disable of Line 02 overvoltage protection	Disable/enable	Disable
	Setting value of Line 02 overvoltage protection	0.01-2000V, 0.01V	500V
	Time limit of Line 02 overvoltage protection	0-100.000s, 0.001s	100.000s
Zero-sequence overvoltage protection	Enable/disable of Line 01 zero-sequence overvoltage protection	Disable/enable	Disable
	Setting value of Line 01 zero-sequence overvoltage protection	0.01-2000V, 0.01V	500V
	Time limit of Line 01 zero-sequence overvoltage protection	0-100.000s, 0.001s	100.000s
	Enable/disable of Line 02 zero-sequence overvoltage protection	Disable/enable	Disable
	Setting value of Line 02 zero-sequence overvoltage protection	0.01-2000V, 0.01V	500V
	Time limit of Line 02 zero-sequence overvoltage protection	0-100.000s, 0.001s	100.000s

Protection element	Name of setting value	Setting range and step size	Factory setting value
Non electricity protection	Enable/disable of non electricity 01 protection	Disable/enable	Disable
	Enable/disable of non electricity 01 tripping	Disable/enable	Disable
	Time limit of non electricity 01 protection	0-100.000s, 0.001s	100.000s
	Enable/disable of non electricity 02 protection	Disable/enable	Disable
	Enable/disable of non electricity 02 tripping	Disable/enable	Disable
	Time limit of non electricity 02 protection	0-100.000s, 0.001s	100.000s
	Enable/disable of non electricity 03 protection	Disable/enable	Disable
	Enable/disable of non electricity 03 tripping	Disable/enable	Disable
	Time limit of non electricity 03 protection	0-100.000s, 0.001s	100.000s
	Enable/disable of non electricity 04 protection	Disable/enable	Disable
	Enable/disable of non electricity 04 tripping	Disable/enable	Disable
	Time limit of non electricity 04 protection	0-100.000s, 0.001s	100.000s
	Enable/disable of non electricity 05 protection	Disable/enable	Disable
	Enable/disable of non electricity 05 tripping	Disable/enable	Disable
	Time limit of non electricity 05 protection	0-100.000s, 0.001s	100.000s
	Enable/disable of non electricity 06 protection	Disable/enable	Disable
	Enable/disable of non electricity 06 tripping	Disable/enable	Disable
	Time limit of non electricity 06 protection	0-100.000s, 0.001s	100.000s
PT disconnection alarm	Enable/disable of I busbar PT disconnection alarm	Disable/enable	Disable
	Enable/disable of I busbar PT disconnection blocking protection	Disable/enable	Disable
	Enable/disable of II busbar PT disconnection alarm	Disable/enable	Disable
	Enable/disable of II busbar PT disconnection blocking protection	Disable/enable	Disable
CT disconnection alarm	Enable/disable of Line 01 CT disconnection alarm	Disable/enable	Disable
	Enable/disable of Line 02 CT disconnection alarm	Disable/enable	Disable
Busbar grounding alarm	Enable/disable of I busbar grounding alarm	Disable/enable	Disable
	Enable/disable of II busbar grounding alarm	Disable/enable	Disable
TWJ abnormal alarm	Enable/disable of Line 01 TWJ abnormal alarm	Disable/enable	Disable
	Enable/disable of Line 02 TWJ abnormal alarm	Disable/enable	Disable
Switch position abnormal alarm	Enable/disable of Line 01 switch position abnormal alarm	Disable/enable	Disable
	Enable/disable of Line 02 switch position abnormal alarm	Disable/enable	Disable
Frequency abnormal alarm	Enable/disable of Line 01 frequency abnormal alarm	Disable/enable	Disable
	Enable/disable of Line 02 frequency abnormal alarm	Disable/enable	Disable

4.1.2. Soft pressure plate

The device is equipped with “common soft pressure plate” and “protection function soft pressure plate”. “Common soft pressure plate is for the system function of the entire device, and “protection function soft pressure plate” is for a specific protection function. The protection is enabled only when both the protection function soft pressure plate and the protection control word are enabled.

Table 4-2-2 Device Soft Pressure Plate List

Common soft pressure plate	Default configuration	Protection function soft pressure plate	Default configuration
Remote modification of setting value	Disable	/	/
Remote switching of setting value area	Disable	/	/
Remote control soft pressure plate	Enable	/	/
Remote/local soft pressure plate	Enable	/	/

“Remote modification of setting value”: When the soft pressure plate is enabled, the device’s setting value can be modified through remote protocol communication. When it is disabled, the setting value can only be modified locally or remotely through the manufacturer’s special debugging software. The soft pressure plate cannot be remotely controlled.

“Remote switching of setting value area”: When the soft pressure plate is enabled, the device’s setting value area can be switched through remote protocol communication. When it is disabled, it can only be switched locally or remotely switched through the manufacturer’s special debugging software. The soft pressure plate cannot be remotely controlled.

“Remote control soft pressure plate”: When this soft pressure plate is enabled, other “protection function soft pressure plates” can be remotely controlled by remote protocol communication. When it is disabled, other “protection function soft pressure plates” can only be enabled and disabled locally, or other “protection function soft pressure plates” can be remotely enabled and disabled through the manufacturer’s special debugging software. This soft pressure plate cannot be remotely controlled.

“Remote/local soft pressure plate”: When the soft pressure plate is enabled, the switch can be remotely controlled through remote protocol communication, and it cannot be remotely controlled when it is disabled. However, the soft pressure plate can be remotely enabled and disabled.

4.1.3. Outlet configuration

The PRS-7342 device provides two independent protection tripping output relays (CJ01-CJ02), CJ01-CJ02 are normally open contacts. The correspondence between relay names and output names is as follows:

Table 4-2-3 Table of Relationship between Relay Name and Output Meaning

Relay name	CJ02	CJ01
Outlet name	Protection tripping output 2	Protection tripping output 1

Each protection can be configured with an independent output as needed, and the corresponding configuration table of the setting value is as follows:

Table 4-2-4 Setting Value Meaning Table

Corresponding setting value (decimal)	Corresponding setting value (binary)	Protection tripping output 2	Protection tripping output 1
0001	0001		√
0002	0010	√	
0003	0011	√	√

Outlet matrix setting value list:

Table 4-2-5 PRS-7342 Tripping Matrix

Protection element	Name of setting value	Setting range and step size	Factory setting value
Tripping matrix	Line 01 Section I overcurrent protection	0001-0008, 0001	0001
	Line 01 Section II overcurrent protection	0001-0008, 0001	0001
	Line 01 Section III overcurrent protection	0001-0008, 0001	0001
	Line 02 Section I overcurrent protection	0001-0008, 0001	0002
	Line 02 Section II overcurrent protection	0001-0008, 0001	0002
	Line 02 Section III overcurrent protection	0001-0008, 0001	0002
	Line 01 Section I negative-sequence overcurrent protection	0001-0008, 0001	0001
	Line 01 Section II negative-sequence overcurrent protection	0001-0008, 0001	0001
	Line 02 Section I negative-sequence overcurrent protection	0001-0008, 0001	0002
	Line 02 Section II negative-sequence overcurrent protection	0001-0008, 0001	0002
	Line 01 Section I zero-sequence overcurrent protection	0001-0008, 0001	0001
	Line 01 Section II zero-sequence overcurrent protection	0001-0008, 0001	0001
	Line 01 Section III zero-sequence overcurrent protection	0001-0008, 0001	0001
	Line 02 Section I zero-sequence overcurrent protection	0001-0008, 0001	0002
	Line 02 Section II zero-sequence overcurrent protection	0001-0008, 0001	0002
	Line 02 Section III zero-sequence overcurrent protection	0001-0008, 0001	0002
	Line 01 low-voltage protection	0001-0008, 0001	0001
	Line 02 low-voltage protection	0001-0008, 0001	0002
	Line 01 overvoltage protection	0001-0008, 0001	0001
	Line 02 overvoltage protection	0001-0008, 0001	0002
	Line 01 zero-sequence overvoltage protection	0001-0008, 0001	0001
	Line 02 zero-sequence overvoltage protection	0001-0008, 0001	0002
	Non electricity protection 01	0001-0008, 0001	0003
	Non electricity protection 02	0001-0008, 0001	0003
Non electricity protection 03	0001-0008, 0001	0003	

Protection element	Name of setting value	Setting range and step size	Factory setting value
	Non electricity protection 04	0001-0008, 0001	0003
	Non electricity protection 05	0001-0008, 0001	0003
	Non electricity protection 06	0001-0008, 0001	0003

Note 1: Non electricity protection defaults to 2 branches. If modification is required, adjust the settings manually.

5. Structure and external characteristics

PRS-7342 box transformer intelligent integrated device adopts a standard 4U half-layer chassis, which is easy to install, with functional design of panels and easy disassembly.

5.1. Opening size

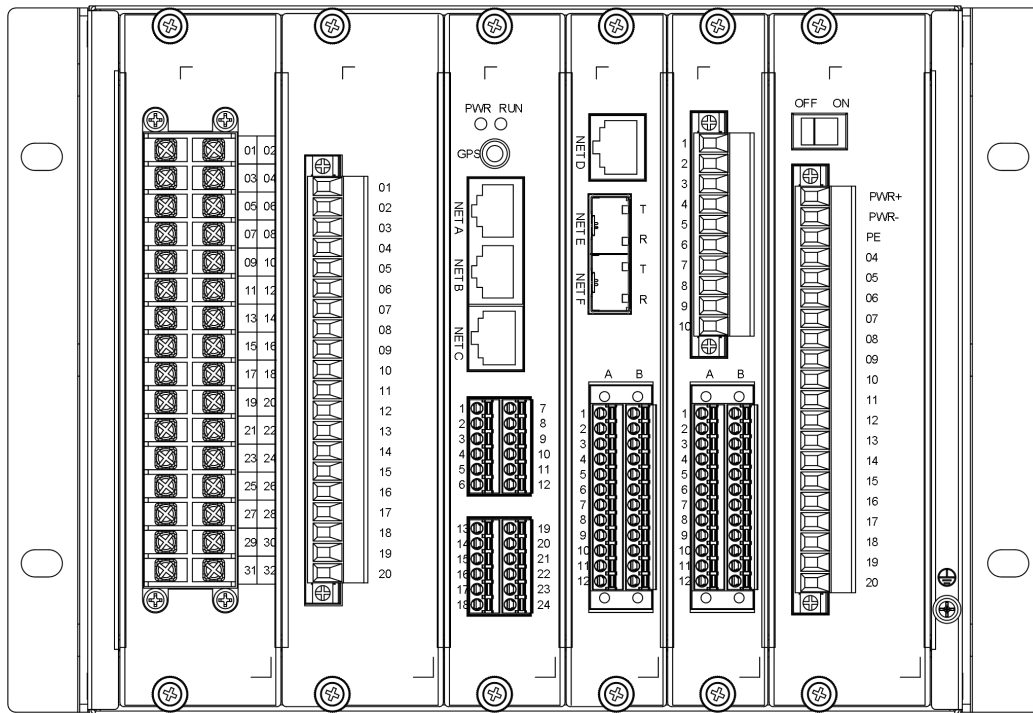

Figure 5-1-1 Back Terminal Diagram

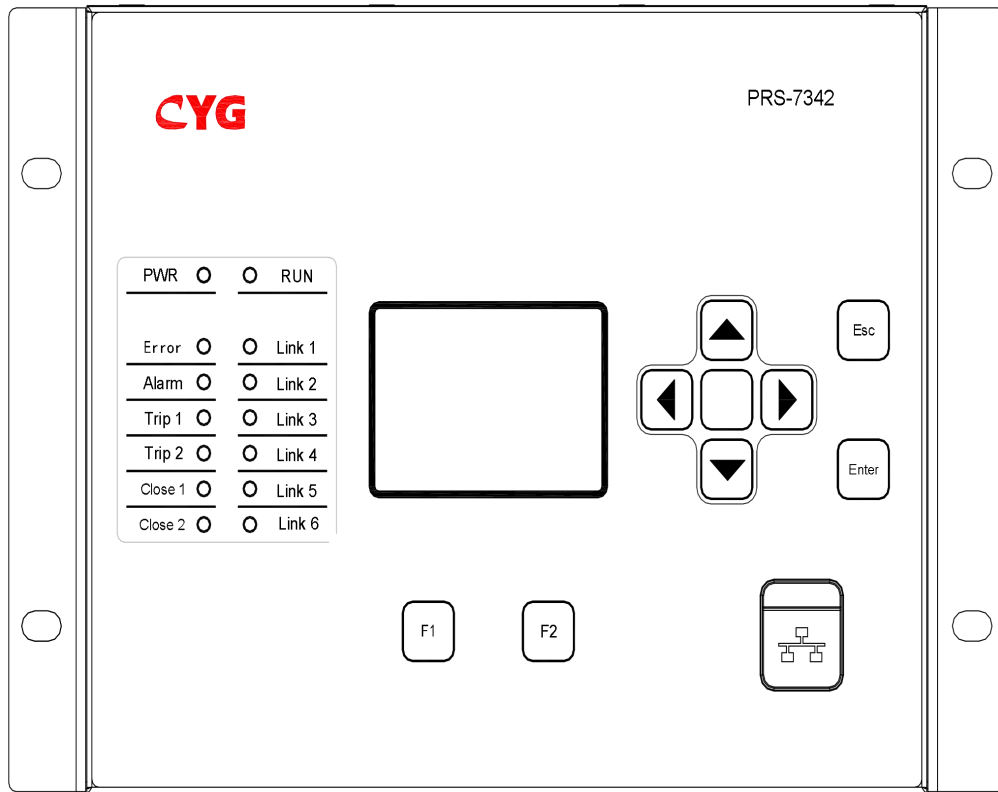

Figure 5-1-2 Front Panel Diagram

5.2. External characteristic definition

Depending on the device model, the device board configuration refers to the following table:

Table 5-2-1 PRS-7342 Board Configuration Table

Serial number	1	2	3	4	5	6
Corresponding lining board	40T	40T	30T	25T	25T	40T
Plug-in function	AC board	DC board	CPU board	Ring network board	IO board	Power supply/IO board

Table 5-2-2 PRS-7342 AC Board SR1181-C0 8U8I Terminal Definition

A		B	
Terminal number	Function definition	Terminal number	Function definition
1	Ua1	1	Ub1
2	Uc1	2	Un1
3	/	3	/
4	Ua2	4	Ub2
5	Uc2	5	Un2
6	/	6	/
7	/	7	/
8	la1	8	la1'

9	lb1	9	lb1'
10	lc1	10	lc1'
11	/	11	/
12	la2	12	la2'
13	lb2	13	lb2'
14	lc2	14	lc2'
15	/	15	/
16	/	16	/

Table 5-2-3 PRS-7342 DC Plug-in SR1183-A0 3RTD5DC Terminal Definition

5.08 standard terminal	
Terminal number	Function definition
1	RTD1-A
2	RTD1-B
3	RTD1-C
4	RTD2-A
5	RTD2-B
6	RTD2-C
7	RTD3-A
8	RTD3-B
9	RTD3-C
10	Null
11	ZL1+
12	ZL1-
13	AGND1
14	ZL2+
15	ZL2-
16	AGND2
17	ZL3+
18	ZL3-
19	AGND3
20	Null

Table 5-2-4 PRS-7342 Input and Output Plug-in SR1383-A0 Terminal Definition

Terminal number	Function definition-A		
1	YKCOM1		
2	YKF1		
3	YKH1		
4	YKCOM2		
5	YKF2		

6	YKH2		
7	Trip 1+		
8	Trip 1-		
9	Trip 2+		
10	Trip 2-		
Terminal number	Function definition-A	Terminal number	Function definition-B
1	KI07 (switch 01 open position)	13	KI18
2	KI08 (switch 01 closed position)	14	KI19
3	KI09 (switch 02 open position)	15	KI20
4	KI10 (switch 02 closed position)	16	KI21
5	KI11	17	KI22
6	KI12	18	KI23
7	KI13	19	KI24
8	KI14	20	KI25
9	KI15	21	KI26
10	KI16	22	KI27
11	KI17	23	KI28
12	KICOM-	24	KI29

Table 5-2-5 PRS-7342 Main Control Plug-in SR1281-B0-G Back Terminal Definition

Terminal number	Terminal type	Function definition-	Interface type	Application notes
NET A	RJ45*3	Ethernet-A	Ethernet	Up-link communication, independent MAC, MMS
NET B		Ethernet-B	Ethernet	Down-link communication, independent MAC, MMS and GOOSE common port
NET C		Ethernet-C	Ethernet	Down-link communication, independent MAC, debug port
1-24	3.81mm 2*6 double row*2	Service-serial port	RS-485 (RS232 optional)*6	3/4, 5/6, 9/10, 11/12 four groups of RS-485, 19/20, 15/16 two groups of RS-485/232 optional, 17/23 is the GND terminal of RS-232
		Time synchronization input	Differential pulse/B code	18/24 terminal

Table 5-2-6 PRS-7342 Power plug-in SR1681-C0 Back Terminal Definition

Terminal number	Function definition	Description
1	Power +	
2	Power -	
3	PE	
4	DC24+	Selective soldering
5	DC24-	Selective soldering

6	Device abnormality +	Normal closed contact required
7	Device abnormality -	
8	XJCOM	Signal common
9	XJ01	Action signal 1
10	XJ02	Alarm signal 2
11	KI01	Device maintenance
12	KI02	Signal reset
13	KI03	Remote handle
14	KI04	Non electricity 01
15	KI05	Non electricity 02
16	KI06	Non electricity 03
17	KI07	Non electricity 04
18	KI08	Non electricity 05
19	KI09	Non electricity 06
20	KICOM-	

Table 5-2-4 PRS-7342 Ring Network Plug-in SR1881-A0 Terminal Definition

Terminal number	Function definition-A		Description
1	Ethernet electrical port		CPU board access ring network 100M communication port
2	Ethernet optical port 1		Gigabit ring network optical port 1
3	Ethernet optical port 2		Gigabit ring network optical port 2
Terminal number	Function definition-A	Terminal number	Function definition-B
1	KI30	13	KI42
2	KI31	14	KI43
3	KI32	15	KI44
4	KI33	16	KI45
5	KI34	17	KI46
6	KI35	18	KI47
7	KI36	19	KI48
8	KI37	20	KI49
9	KI38	21	KI50
10	KI39	22	KI51
11	KI40	23	KI52
12	KI41	24	KICOM-

6. Device order description

6.1. Basic ordering parameters

When the PRS-7342 new energy intelligent integrated box transformer terminal is used in a project, the user is generally required to provide the following information and parameters:

- (1) Occasions of use, such as box-type transformer substations in photovoltaic power plants or wind power plants;
- (2) Number of switches to be monitored, up to 2 transformer branches can be monitored;
- (3) AC power supply specifications (DC24V);
- (4) Rated AC voltage (line voltage 100V), rated secondary current (5A/1A);
- (5) Cabinet size requirements;
- (6) Main wiring diagram of the primary system;
- (7) System neutral point grounding method;
- (8) Communication interface method.

If there are special requirements in terms of protection configuration, operation circuit, measurement and control, remote control, etc., please explain it in the technical agreement.

Appendix A Device usage instructions

Note 1: This section is a general description; the auxiliary function configuration may be slightly different for different device models.

Note 2: The viewing and setting of device data and records can be completed through the local display interface and operation keyboard, or through the remote interface, depending on the actual device configuration, the content and function are exactly the same.

A.1. Panel layout and display

A.1.1. Signal lights

The device provides 7 types of signal lights to reflect the operation status of the device in real time.

Table A-1-1 Definition of Light Film of PRS-7342 Integrated Box Transformer Terminal Device

Serial number	Name	Color	Meaning
1	Power supply	Green	The device is always on when it is powered on.
2	Operation	Green	On: The device is always on if the self-test is passed after power-on. Off: When the device cannot work or some functions are missing due to hardware or software abnormalities, it is in a always off state.
3	Abnormal	Red	On: The device is always on when there is an abnormality in the hardware, software or configuration. Off: The device is operating normally.
4	Trip 1	Red	Line 1 protection tripping indicator, lights up after line 1 protection trips, red, disappears after the fault returns and resets.
5	Trip 2	Red	Line 2 protection tripping indicator, lights up after line 2 protection trips, red, disappears after the fault returns and resets.
6	Closed position 1	Green	Line 1 closed position indicator, lights up after line 2 closed position is detected, red, disappears after line 2 closed position is returned.
7	Closed position 2	Green	Line 2 closed position indicator, lights up after line 2 closed position is detected, red, disappears after line 2 closed position is returned.

A.1.2. Panel layout and key definition

Table A-1-2 Key Function Definition Table

Serial number	Key name	Key printing	Key basic function
1	Up key	▲	Move cursor up
2	Down key	▼	Move cursor down
3	Left key	◀	Move cursor left
4	Right key	▶	Move cursor right
5	Standby	Standby	Switch primary and secondary value display
6	Reset	Reset	Reset
7	Confirm key	Confirm	Confirm execution of operation
8	Return key	Return	Cancel operation

A.2. Menu interface operation instructions

The menu of the device includes level 1, level 2, level 3, and level 4 menus. The level 1 menu includes 4 items: view, set, and preset.

In the main interface of the device, press the “Confirm” key to enter the level 1 menu interface, which displays a right-pull menu in Chinese. The menu display interface is divided into two windows. The left window is the menu list, and the lower window is the description of the corresponding menu option, which prompts the content of the option, the operations that can be performed under the option, or other information that requires special attention.

The menu list of the integrated box transformer device is as follows (displayed to the level 3 menu):

Table A-2-1 Menu Interface Operation Instructions

Level 1 menu	Level 2 menu	Level 3 menu	Description	
View	Device information		View the device model, software version, CRC check code, software date, device uniqueness code and other information.	
	Protection AC quantity		View the network port IP and MAC address.	
	Telemetry information		View the AC quantities, DC quantities, harmonic quantities, and power quantities of the corresponding lines.	
	Remote signaling information	Remote signaling input		All the original input quantities of the device and their maintenance status can be viewed Each input quantity is displayed on one line. The input quantity is displayed in pages. Press the ▲, ▼, ◀, ▶ keys to flip pages.
		Double-point remote signaling		Check the closing and opening channels of each double-point remote signaling.
	Device parameters		The “device parameter setting” of the device can be checked.	
	Protection setting value		The protection setting value of the device is divided into two categories: “numerical setting value” and “protection control word”. The numerical setting value is grouped by function (each group of setting value can be displayed in multiple pages, and the pages can be flipped by pressing the ◀ and ▶ keys). The display of each setting value occupies one line. The setting value viewing item under the menu is designed to facilitate the viewing of the current protection setting status. It does not respond to any modification operation during viewing, and will not exit the protection.	
	Protection control word		It includes the status of the device's input quantities: maintenance status, reset, and remote operation.	
	Tripping matrix		Check the tripping matrix output.	
	Soft pressure plate		Check the status of the remote/local soft pressure plate, remote enable and disable pressure plate soft pressure plate, remote switching of setting value area soft pressure plate, and remote modification of setting value soft pressure plate.	
	Device record	Operation report		The first record is the latest record, the second is the latest, and so on; if there is no valid record, “No XXXX record” will be displayed.
		Protection action		
		Protection alarm		The content of the device record generally includes the record generation time (from year to milliseconds) and the record item name and change status. For the specific format of each record, please refer to the detailed description in the “4.2 Accident Analysis and Process Record” section. The capacity of each record of the device is different, and it can be displayed in multiple pages. Pressing the ▲, ▼, ◀, and ▶ keys can flip pages. The specific definition is: pressing the ▲ key increases the page number by 1, pressing the ▼
Protection start				
Protection blocking record				
SOE record				
Remote control record				

Level 1 menu	Level 2 menu	Level 3 menu	Description
		Self-test record	key decreases the page number by 1, pressing the ◀ key decreases the page number by 10, and pressing the ▶ key increases the page number by 10.
		Running record	
		Operation record	
	Wave recording information	Action wave recording	View the saved action wave recording, historical start wave recording information and manual wave recording information of the device.
		Start wave recording	
		Manual wave recording	
Setting	Setting value area number		The device can store up to 2 groups of setting values, 01 to 02. After the setting value group is selected, the following settings are all for the selected setting value group.
	Device parameters		According to the on-site device parameters, the setting is mainly PT primary value, CT primary and secondary values of each branch, and primary and secondary values of the reference CT. For unused intervals, set the CT primary value to 0.
	Protection setting value		This menu is used to set the numerical setting value of the current zone. The setting method of "numerical setting value" is: press ▲, ▼ keys to select the setting value group to be set, and press "Confirm" key to enter the setting value content display interface of this group. The underline cursor is where the content can be changed. Press the ◀ or ▶ key to select the corresponding bit. Press "Confirm" to highlight the bit. Press the ▲ or ▼ key to increase or decrease the number. Press the "Confirm" key to confirm the change. Press the "Return" key to cancel the change. If the changed value exceeds the effective range of the device's default setting value, press "Confirm" and the device will automatically display the "maximum value" within the setting range of the setting value.
	Protection control word		This menu is for setting the protection control word of the current zone. All setting operations of the "protection control word" are exactly the same as those of the "numerical setting value". Its changeable status is "0" and "1". In the highlighted state, press the ▲, ▼, ◀, and ▶ keys to switch between the two. After a certain group (numeric value or enable and disable) of setting values is set, directly press the ◀ or ▶ keys to flip the page to enter the setting (or viewing) of other groups of setting values. After confirming that all the settings that need to be set have been completed, press the "Return" key to exit this menu. At this time, the device displays the following menu, and the next operation in it needs to be selected to exit the current setting state.
	Tripping matrix		The tripping matrix outlet can be set.
	Soft pressure plate		It includes the remote/local soft pressure plate, remote enable and disable soft pressure plate, remote switching of setting value zone soft pressure plate, and remote modification of setting value soft pressure plate. Select the soft pressure plate to be modified, press ◀, ▶ to modify the value, "0" means the soft pressure plate is closed, "1" means the soft pressure plate is open. After setting the parameters, press the "Return Key", select "Download Parameters" to make the parameter settings effective, and select "Cancel Setting" to return to the menu.
	Setting value copy		The source setting value group can be copied to the destination setting value group.
Preset	Time synchronization mode		Set the device time synchronization mode.

Level 1 menu	Level 2 menu	Level 3 menu	Description
	Clock setting	Date and time	Set the device time, from year to second. Note: The device can also be synchronized through a time synchronization device or software.
	Remote control settings	Remote control pulse width	Set the remote control pulse width. The remote control pulse width of each remote control opening and closing channel can be set. Press "Confirm" to highlight the item. Press ▲ and ▼ keys to increase or decrease the number (▲ for "add 1" and ▼ for "subtract 1"). The options are: 50ms, 100ms, 200ms, 300ms, 400ms, 500ms, 600ms, 700ms, 800ms, 900ms, 1s, 2s, 5s, 10s, 20s, 30s, 40s, 50s, 60s.
	Telemetry setting	Power calculation method	"Two-meter method" or "three-meter method" can be selected.
		DC transmitter parameters	The RTD temperature measurement method can be selected.
		AC board model	Select the AC board type.
		Telemetry fine-tuning coefficient	Coefficient setting range: -100~+100, fine-tuning value = (fine-tuning coefficient/1000) * rated value.
		Telemetry flying point threshold	Set the telemetry flying point threshold.
	Remote signaling setting	Remote signaling anti-jitter time	The anti-jitter time of each remote signaling can be set. The options are: 5ms, 7ms, 10ms, 20ms, 40ms, 80ms, 100ms, 200ms, 300ms, 400ms, 500ms, 600ms, 700ms, 800ms, 900ms, 1s, 2s, 5s, 10s, 20s, 30s, 40s, 50s, 60s, no anti-jitter.
		Double-point remote signaling	Set the closing and opening channels of each double-point remote signaling.
	Auxiliary functions	Forced reset	Reset action events, alarm events, device abnormalities, and accident reports, a total of 4 items, can be selected and operated according to the menu prompts. Note: If the corresponding fault has not disappeared or the event has not returned, the event cannot be reset, and any self-test information of the device cannot be reset under this operation. In these cases, the "Forced reset" item can be used for forced reset.
		Manual wave recording	It is used to start the "manual wave recording" function of the device. Press the "Confirm" key to start manual wave recording, and press the "Return" key to return. The manual wave recording information can be viewed in the device's [View] menu. (Note that saving and reading the wave recording waveform takes a certain amount of time.)
		Clear records	It is used to clear various records of the device, including action reports, action records, alarm records, startup records, position change records, self-test records, etc., a total of 8 items, follow the menu prompts. If there is no device record option in this project, it means that the corresponding record cannot be cleared.
	Communication parameters	Device number	Set the communication address number of the device, which is used for communication identification with the upper computer. The device number corresponds to the last three digits of the device network port.
		Network port setting	Set the IP address of the device Ethernet network port.
		Sntp time synchronization setting	Set the SNTP server IP.
	Main interface phase reference	Set the analog display phase reference	The phase reference of the AC quantity displayed on the device inspection interface can be set.

Appendix B Device debugging and commissioning instructions

B.1 Preparation of debugging materials

- 1) Device manual and the panel assembly design drawings of the tested panel;
- 2) Design albums related to the connection between the tested panel and other external circuits from the design institute.

B.2 Check before power on

- 1) Remove all pressure plates and disconnect all air switches;
- 2) Check whether the model and parameters of the device are consistent with the order, and pay attention to whether the rated voltage matches the site;
- 3) Check whether the plug-in is loose, whether the device has mechanical damage, and whether the position of each plug-in is consistent with the position specified in the drawing;
- 4) Check whether the wiring has phenomena such as loose crimps or broken wires;
- 5) Use a multimeter to check whether the power circuit is short-circuited or open-circuited;
- 6) Confirm that the device is reliably grounded.

B.3 Power-on check

- 1) Close the power air switch, and then close the small boat-shaped switch on the power board;
- 2) After power-on, the "PWR" power indicator lights up. If the device software starts to run normally, the device operation indicator "RUN" lights up at this time, which can simply determine whether the CPU board and program are normal;
- 3) Whether the communication indicator between the main control board and each AC board displayed on the main control board flashes normally;
- 4) Whether the power indicator on the I/O board is always on, and whether the communication indicator flashes;
- 5) If it is the first time to power on, the clock can be adjusted through the device maintenance software;
- 6) Check the parameter settings of the device. If the factory default settings of the device do not meet the on-site requirements, refer to the device instructions for use and make corresponding settings.

B.4 Whole machine debugging

The whole machine debugging of the device is carried out according to the following basic steps (please refer to the device debugging outline for the specific content and operation instructions of each item):

1) Power supply test

Check whether the actual power supply matches the device power supply. If the power supply is correct, power on the device. For details, see the debugging instructions for the intelligent protection and measurement and control device.

2) Telemetered AC quantity debugging

During debugging, input the rated power frequency power at the terminal according to the wiring diagram of the device to check whether each AC quantity is accurate. Calibration can be performed through the maintenance software. For details, see the debugging instructions for the intelligent protection and measurement and control device.

3) Input quantity debugging

Add input voltage to the corresponding external terminal, and use the human-machine interface or device maintenance software to check whether the position change of each input quantity is correct. Check whether the input quantity and SOE record and COS record correspond.

4) Output quantity debugging

Use the human-machine interface or device maintenance software to check each remote control outlet. Check whether the contact, indicator light, and relay hardware circuit are correct.

5) Protection function debugging

See the device manual and verify whether the logic is correct according to the specific configuration of the engineering software.

6) Signal light and button test

Check whether the remote/local indicator light of the panel cabinet, the switch closing position, the switch jump position indicator light, the reset button, etc. are normal.

7) Communication function debugging

Check the device Ethernet port to see if it can establish IEC104 protocol communication with the master station, whether it can correctly send remote signaling, telemetry, and telepulse, and respond to the master station's remote control, time calibration and other commands.

Check the serial port of the device to see if it can establish communication with other devices and correctly collect information from other devices.

8) After debugging, the debugging records should be archived and compared with the factory debugging records.

B.5 Operation steps for putting the device into operation

- 1) Confirm that all pressure plates are disabled;
- 2) Check the cables to confirm that they are consistent with the installation drawings, and confirm that all temporary wiring and anti-error measures have been restored;
- 3) Turn on the power supply;
- 4) Verify that the AC circuit is good, and there is no abnormality in the voltage and current amplitude and its phase;
- 5) Check the device clock;
- 6) After the device is checked and no problems, the corresponding pressure plate, and the device is officially put into operation;
- 7) After the device is operating normally, various information and records can be viewed.

B.6 Device operation instructions

When the device is running, the signal light on the panel can reflect the operation status.

When the device works abnormally or there are difficult problems, the device records should be saved in time for analysis, and contact should be made with the manufacturer.

Appendix C Differential protection setting calculation

C.1 CT wiring principle

The PRS-3342GA new energy intelligent integrated box transformer terminal requires that the CTs on each side of the transformer are connected in a Y-shape, and that the CTs on each side are connected in the same polarity, with the busbar side as the polarity end.

C.2 Differential current calculation formula

The PRS-3342GA new energy intelligent integrated box transformer terminal has high and low-voltage sides. The calculated differential current and braking current are shown in Table C-2-1. The high and low-voltage sides are represented by subscripts H and L respectively.

Table C-2-1 Differential/braking Current Calculation Formula

Differential current	Braking current
$I_{da} = I_{Ha'} + I_{La'}$ $I_{db} = I_{Hb'} + I_{Lb'}$ $I_{dc} = I_{Hc'} + I_{Lc'}$	$I_{ra} = (I_{Ha'} + I_{La'}) / 2$ $I_{rb} = (I_{Hb'} + I_{Lb'}) / 2$ $I_{rc} = (I_{Hc'} + I_{Lc'}) / 2$

C.3 Transformer star connection phase compensation

The high-voltage side wiring of the PRS-3342GA new energy intelligent integrated box transformer terminal series device uses Y-type wiring, and the “high-voltage side wiring method” needs to be set to 0. The phase of the CT secondary current on each side of the transformer is adjusted by software. This device uses $Y \rightarrow \Delta$ transformation for phase correction. Taking the Y/Y Δ -11 wiring method as an example, the phase correction method is as follows:

The $Y \rightarrow \Delta$ conversion diagram of the CT secondary current is shown below:

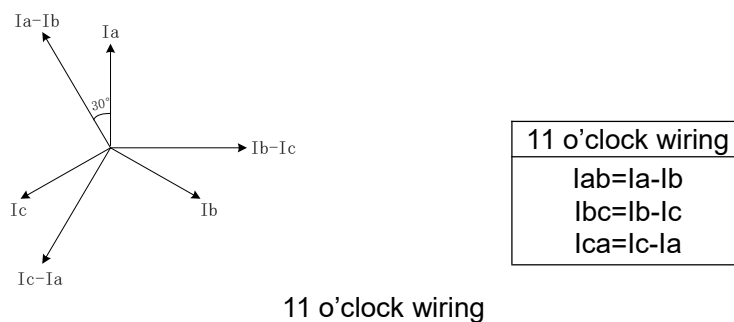

Table C-3-1 Schematic Diagram of $Y \rightarrow \Delta$ Conversion of Secondary Current

This device only performs phase correction on the Y side current. If the Δ side is wired at 11 o'clock, the Y side phase correction method is as follows:

$$I'_A = (I_A - I_B) / \sqrt{3} \tag{C-3-1}$$

$$\dot{I}'_B = (\dot{I}_B - \dot{I}_C) / \sqrt{3} \quad (\text{C-3-2})$$

$$\dot{I}'_C = (\dot{I}_C - \dot{I}_A) / \sqrt{3} \quad (\text{C-3-3})$$

The Δ side phase does not need to be corrected, and the processing method is as follows:

$$\dot{I}'_A = \dot{I}_A \quad (\text{C-3-4})$$

$$\dot{I}'_B = \dot{I}_B \quad (\text{C-3-5})$$

$$\dot{I}'_C = \dot{I}_C \quad (\text{C-3-6})$$

[Note]: For transformers with Y connection on each side, although there is no phase difference between the CT secondary currents on each side, in order to eliminate the influence of the zero-sequence current on the Y side on the differential protection, all Y side currents must also be processed according to formulas (C-3-1) to (C-3-3).

C.4 Calculation of rated current I_e for longitudinal differential protection

- 1) Primary rated current I_{1e} on each side of the transformer:

$$I_{1e} = \frac{S_n}{\sqrt{3}U_{1n}} \quad (\text{C-4-1})$$

Where: S_n is the maximum rated capacity on the transformer nameplate, and U_{1n} is the primary rated voltage on the transformer calculation side.

- 2) CT transformation ratio K_{TA} on each side of the transformer:

$$K_{TA} = \frac{\text{CT primary on the calculation side}}{\text{CT secondary rated current}} \quad (\text{C-4-2})$$

Where: CT secondary rated current is 5A or 1A (PRS-3342GA secondary rated current is 1A), and "CT primary on the calculation side" is determined by the corresponding setting value of the system parameters.

- 3) Secondary rated current I_{2e} on each side of the transformer:

$$I_{2e} = \frac{I_{1e}}{K_{TA}} \quad (\text{C-4-3})$$

The calculated secondary rated current I_{2e} on the high-voltage side is the rated current I_e used for the calculation of longitudinal differential protection.

C.5 Calculation of longitudinal differential CT balance coefficient

Calculation of CT balance coefficient on each side of longitudinal differential protection, taking the high-voltage side as the reference, the balance coefficient on the high-voltage side is fixed to 1. Taking the balance coefficient on the low-voltage side as an example, the calculation process is as follows:

1) Primary rated current on the high-voltage side and the low-voltage side

Primary rated current I_{1e-H} on the high-voltage side:

$$I_{1e-H} = \frac{S_n}{\sqrt{3}U_{1n-H}} \quad (\text{C-5-1})$$

Primary rated current I_{1e-L} on the low-voltage side:

$$I_{1e-L} = \frac{S_n}{\sqrt{3}U_{1n-L}} \quad (\text{C-5-2})$$

2) CT transformation ratio on the high-voltage side and the low-voltage side

CT transformation ratio K_{TA} on the high-voltage side:

$$K_{TAH} = \frac{\text{CT primary on the high-voltage side}}{\text{CT secondary rated current on the high-voltage side}} \quad (\text{C-5-3})$$

CT transformation ratio K_{TAL} on the low-voltage side:

$$K_{TAL} = \frac{\text{CT primary on the low-voltage side}}{\text{CT secondary rated current on the low-voltage side}} \quad (\text{C-5-4})$$

Where: CT secondary rated current is 5A or 1A (PRS-3342GA secondary rated current is 1A), and

“CT primary on the calculation side” is determined by the corresponding setting value of the system parameters.

3) Secondary rated current on the high-voltage side and the low-voltage side

Secondary rated current I_{2e-H} on the high-voltage side :

$$I_{2e-H} = \frac{I_{1e-H}}{K_{TAH}} \quad (\text{C-5-5})$$

Secondary rated current I_{2e-L} on the low-voltage side:

$$I_{2e-L} = \frac{I_{1e-L}}{K_{TAL}} \quad (\text{C-5-6})$$

4) Longitudinal differential protection low-voltage side balance coefficient

Low-voltage side balance coefficient K_{phL-ZC} :

$$K_{phL-ZC} = \frac{I_{2e-H}}{I_{2e-L}} = \frac{I_{1eH} / K_{TAH}}{I_{1eL} / K_{TAL}} = \frac{S_n / \sqrt{3} U_{1nH}}{S_n / \sqrt{3} U_{1nL}} \cdot \frac{K_{TAL}}{K_{TAH}} = \frac{U_{1nL}}{U_{1nH}} \cdot \frac{K_{TAL}}{K_{TAH}} \quad (\text{C-5-7})$$

In formula (C-5-7), K_{TAL} is the CT transformation ratio of the low-voltage side switch, and U_{1nL} is the rated voltage of the low-voltage side.

Appendix D Protection setting value error range

D.1 Three-stage directional overcurrent protection

Action current setting value:

Setting range: 0.1-10A.

Error: not more than $\pm 5\%$ or $\pm 0.01A$.

Inherent action time: $\leq 40ms$.

Delay setting value:

Setting range: 0-10s.

Error: not more than $\pm 1\%$ or $\pm 40ms$

Low-voltage block setting value:

Low-voltage block setting range: 10~100V

Error: not more than 5% or $\pm 0.1V$.

D.2 Two-stage negative-sequence overcurrent protection

Action current setting value:

Setting range: 0.1-10A.

Error: not more than $\pm 5\%$ or $\pm 0.01A$.

Inherent action time: $\leq 40ms$.

Delay setting value:

Setting range: 0-10s.

Error: not more than $\pm 1\%$ or $\pm 40ms$

D.3 Three-stage zero-sequence directional overcurrent protection

Action current setting value:

Setting range: 0.1-10A.

Error: not more than $\pm 5\%$ or $\pm 0.01A$.

Inherent action time: $\leq 40ms$.

Delay setting value:

Setting range: 0-10s.

Error: not more than $\pm 1\%$ or $\pm 40\text{ms}$

D.4 Low-voltage protection

Action voltage setting value:

Setting range: 10-80V.

Error: no more than $\pm 5\%$.

Inherent action time: $\leq 40\text{ms}$.

Delay setting value:

Setting range: 0-10s.

Error: no more than $\pm 1\%$ or $\pm 40\text{ms}$.

D.5 Overvoltage protection

Action voltage setting value:

Setting range: 50-150V.

Error: no more than $\pm 5\%$.

Inherent action time: $\leq 40\text{ms}$.

Delay setting value:

Setting range: 0-10s.

Error: no more than $\pm 1\%$ or $\pm 40\text{ms}$.

D.6 Zero-sequence overvoltage protection

Setting range: 50-150V.

Error: no more than $\pm 5\%$.

Inherent action time: $\leq 40\text{ms}$.

Delay setting value:

Setting range: 0-10s.

Error: no more than $\pm 1\%$ or $\pm 40\text{ms}$.

D.7 Non electricity protection

Delay setting value:

Setting range: 0-10s.

Error: no more than $\pm 1\%$ or $\pm 40\text{ms}$.

D.8 Longitudinal differential protection

Action current setting range: $0.05I_e \sim 5I_e$, error not more than $\pm 2.5\%$ or $\pm 0.02I_n$

Action time: $\leq 1\%$ or $\pm 40\text{ms}$ (excitation quantity ≥ 2 times setting value)

Two-stage ratio braking coefficient: $K_1=0.5$, $K_2=0.75$, error not more than $\pm 5\%$