



HG Insulator Co., Ltd.,(HG Insulator), established on 2018, is a controlled subsidiary company of CYG Insulator. All the manufacturing and processing technology are moved from CYG Insulator and all the technical & management systems are all from CYG Insulator. Together with the 35 years' operation experience from Huaxin, HG Insulator focus on the composite hollow insulators, composite porcelain hollow insulators and composite post insulators.

HG Insulator sets up three lean production lines in phase I stage. Its mainly products are the composite hollow insulators up to 500kV with the annual production capacity of 20000 pieces(Calculation on 126KV hollow insulators). It also has the design, type, acceptable and routine testing ability, covering the incoming raw material lever, semi-product lever and finished products lever.

HG Insulator's products are popular used in substation region, Hollow Insulators mainly in CT/CVT, GIS, Breaker, Arrestor and Cable Terminal etc and Post Insulators mainly in BPI, HV Switch and RPI. Its reliable quality has been recognized and praised by various consumers both domestic and at abroad, including the world famous groups such as ABB, Siemens, GE, WOER, , ARTECHE etc.

H&G Insulator is certified by ISO 9001/ISO14001/ISO45001

COMPANY PROFILE



COMPOSITE POST INSULATOR FOR SUBSTATION (SOLID AND HOLLOW CORE TYPE)

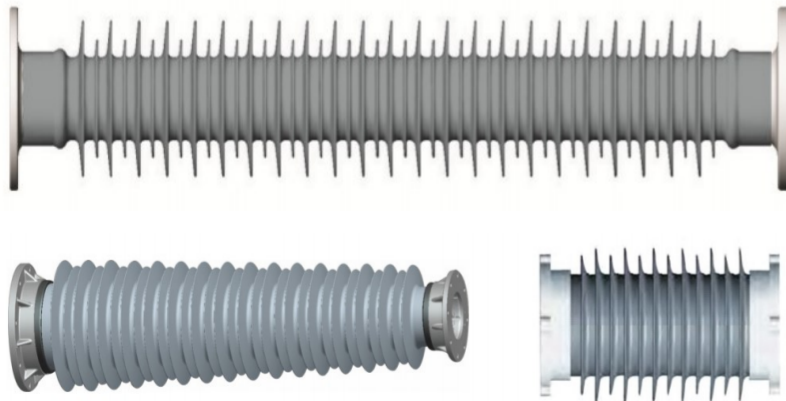

Composite Solid and Hollow Core Post Insulators offer the ultimate solution in improved performance. Because of its hydrophobicity, this material inherently resists water filming thereby limiting leakage currents. Insulators with reduced leakage currents, even when contaminated, require less frequent washing. The savings in such maintenance costs are added benefits of using silicone insulators.

Application: Composite Solid and Hollow Core Post Insulators are used for insulation and mechanical fixation of busbars and electrical equipment in power plants and substations, including post composite insulators for reactors, busbars, and isolation switches. Hollow composite insulator commonly used in high-voltage electrical equipment such as GIS combination switches, transformers, transformers, capacitors, lightning arresters, cable accessories, wall bushings, etc.

Component: Composite Solid Core Post Insulators are consisted of a core rod, end fittings, and a silicone rubber sheds and sheaths. Composite Hollow Core Post Insulators are composed of aluminum alloy flanges, glass fiber reinforced resin sleeves, and silicone rubber sheds and sheaths.

Technology Innovation: For HTV SR, H&G has its own patent formula and its own patent of the production process; For process, H&G creates the unique whole molding injection/sealing

COMPOSITE SOLID CORE POST INSULATORS CATAGLOGUES

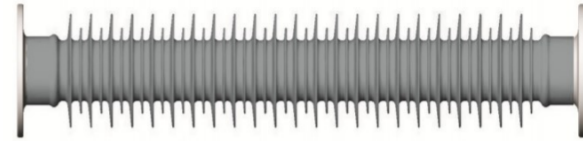

SN	Technical Reference Number	Designation	Voltage (kV)	Height (mm)	Tolerance (mm)	PCB(mm)	Minimum Leakage Distance (mm)	SCL (kN)	STL (kN)	Compression Strength (kN)	Torsional Strength (kN)	Critical Flahover Positive ANSI(KV)	Low Frequency Wet withstand Voltage ANSI (kV)	Impulse Withstand (BIL) ANSI (kV)
1	TR202	CSP 8.9 FF 95/267-190.5	10	190.5	1	76	267	8.9	40	40	0.7	105	30	95
2	TR205	CSP 8.9 FF 110/274-254	15	254	1	76	394	8.9	40	40	0.7	125	40	110
3	TR208	CSP 8.9 FF 150/610-355.6	27	355.6	1	76	610	8.9	45	45	0.7	165	60	150
4	TR210	CSP 8.9 FF 200/864-457.2	36	457.2	1	76	940	8.9	45	45	0.7	225	80	200
5	TR214	CSP 8.9 FF 250/1092-558.8	46	558.8	1	76	1092	8.9	45	45	0.7	280	100	250
6	TR216	CSP 6.7 FF 350/1829-762	69	762	1	76	1829	6.7	72	72	0.7	390	145	350
7	TR222	CSP 17.8 FF 95/267-190.5	10	190.5	1	127	267	17.8	72	72	0.7	105	30	95
8	TR225	CSP 17.8 FF 110/394-254	15	254	1	127	394	17.8	72	72	0.7	125	45	110
9	TR227	CSP 17.8 FF 150/610-355.6	27	355.6	1	127	610	17.8	72	72	0.7	170	60	150
10	TR231	CSP 17.8 FF 200/940-457.2	36	457.2	1	127	940	17.8	72	72	0.7	225	80	200
11	TR267	CSP 17.8 FF 250/1092-558.8	46	558.8	1	127	1092	17.8	72	72	0.7	280	100	250
12	TR278	CSP 13.3 FF 350/1524-762	69	762	1	127	1524	13.3	78	78	0.7	390	145	350
13	TR279	CSP 17.8 FF 350/1524-762	69	762	1	127	1524	17.8	78	78	1.6	390	145	350
14	TR286	CSP 7.6 FF 550/2515-1143	115	1143	2	127	2515	7.6	78	78	1.6	610	230	550
15	TR287	CSP 11.6 FF 550/2515-1143	115	1143	2	127	2515	11.6	78	78	1.6	610	230	550

16	TR288	CSP 6.2 FF 650/2946-1371.6	138	1371.6	2	127	2946	6.2	78	78	1.6	710	275	650
17	TR289	CSP 9.8 FF 650/2946-1371.6	138	1371.6	2	127	2946	9.8	78	78	2.0	710	275	650
18	TR291	CSP5.3 FF 750/3353-1574.8	161	1574.8	3	127	3353	5.3	78	78	2.0	810	315	750
19	TR295	CSP8.2 FF 750/3353-1574.8	161	1574.8	3	127	3353	8.2	78	78	2.0	810	315	750
20	TR304	CSP 4.2 FF 900/4191-2032	230	2032	3.5	127	4191	4.2	78	78	2.0	1010	385	900
21	TR308	CSP 6.4 FF 900/4191-2032	230	2032	3.5	127	4191	6.4	78	78	2.0	1010	385	900
22	TR312	CSP3.5 FF 1050/5029-2336.8	230	2336.8	3.5	127	5029	3.5	78	78	2.0	1210	455	1050
23	TR316	CSP5.6 FF 1050/5029-2336.8	230	2336.8	3.5	127	5029	5.6	78	78	2.0	1210	455	1050
24	TR324	CSP 4.4 FF 1300/5868-2692.4	252	2692.4	4	127	5868	4.4	111.2	111.2	5.6	1410	525	1300
25	TR330	CSP 4 FF 1470/6706-3098.8	345	3098.8	5	127	6706	4	111.2	111.2	5.6	1610	590	1470
26	TR379	CSP 7.6 FF 1550/7112-3252	420	3252	4.7	127-178	7112	7.6	112	95	10	1710	620	1550
27	TR391	CSP 6.3 FF 1800/8382-3861	550	3861	5.5	127-178	8382	6.3	112	67	10	2000	710	1800

Remark:

- 1) All the designs are in accordance with the ANSI/IEC relative standards and can also be customized as per actual request.
- 2) The other type of end fittings are also available if needed.

CATAGLOGUE FOR HOLLOW CORE POST INSULATORS



SN	Voltage (kV)	Height (mm)	MML (kN.m)	SML (kN)	MSP (Mpa)	SIP (Mpa)	Pollution Level (mm/kV)	Pipe Inner Diameter (mm)	Pipe Outer Diameter (mm)	Pipe Type
1	550	5285	98	245	0.8	3.2	31	Φ350	Φ400	Straight Pipe
2	550	5300	98	245	0.8	3.2	31	Φ350	Φ400	Straight Pipe
3	550	5035	50	125	1	4	31	Φ482	Φ510	Straight Pipe
4	550	5635	50	125	1	4	31	Φ482	Φ510	Straight Pipe
5	550	4010	23.6	59	0.8	3.2	25	Φ270	Φ290	Straight Pipe
6	420	3364	23.6	59	0.8	3.2	25	Φ270	Φ290	Straight Pipe
7	252	1645	4	10	1	4	31	Φ100/Φ113	Φ137	Straight Pipe
8	252	2746	16	50	1	4	31	Φ375	Φ400	Straight Pipe
9	252	2500	20	50	1	4	31	Φ248	Φ272	Straight Pipe
10	245	1395	4	10	1	4	31	Φ100/Φ113	Φ137	Straight Pipe
11	245	1465	4	10	1	4	31	Φ100/Φ113	Φ137	Straight Pipe
12	220	2249	8	20	0.8	3.2	31	Φ300	Φ320	Straight Pipe
13	170	1510	7.5	21.2	1.2	4	31	Φ240	Φ260	Straight Pipe
14	170	1570	7.5	21.2	1	4	31	Φ240	Φ260	Straight Pipe
15	170	1500	9	22.5	1.2	2.4	31	Φ240	Φ260	Straight Pipe
16	170	1500	15	37.5	1.1	4.4	31	Φ375	Φ400	Straight Pipe
17	170	1180	4	10	1	4	20	Φ100/Φ113	Φ137	Straight Pipe
18	145	1406	15.6	6.3	0.8	3.2	31	Φ154	Φ174	Straight Pipe
19	126	1410	5.6	14	1	4	31	Φ200/Φ180	Φ218	Straight Pipe

20	126	1360	5.6	14	1	4	31	Φ200/Φ180	Φ218	Straight Pipe
21	126	1338	3.2	8	0.8	3.2	31	Φ140	Φ160	Straight Pipe
22	126	1430	18	12	0.8	3.2	31	Φ230	Φ250	Straight Pipe
23	126	1400	5.2	13	0.8	3.2	31	Φ182	Φ200	Straight Pipe
24	72.5	886	7	17.5	1	4	31	Φ200/Φ180	Φ218	Straight Pipe
25	72.5	750	4.06	10.15	0.8	3.2	31	Φ83	Φ110	Straight Pipe
26	72	792	2	5	0.8	3.2	31	Φ400	Φ414	Straight Pipe
27	40.5	590	12	30	0.8	3.2	31	Φ200	Φ224	Straight Pipe
28	40.5	600	12	30	0.8	3.2	31	Φ200	Φ224	Straight Pipe
29	36	460	12	30	0.8	3.2	25	Φ200	Φ224	Straight Pipe
30	35	632	3.2	8	0.8	3.2	31	Φ130	Φ160	Straight Pipe
31	35	1010	3.2	8	0.8	3.2	31	Φ130	Φ160	Straight Pipe
32	35	520	3.8	9.4	1	4	31	Φ130	Φ147	Straight Pipe
33	252	2400	13.44	33.6	1	4	31	Φ330/Φ180	Φ355/Φ205	Cone Pipe
34	252	2570	36	14.4	1	4	31	Φ330/Φ180	Φ355/Φ205	Cone Pipe
35	252	2700	16	40	1	4	31	Φ360/Φ180	Φ380/Φ200	Cone Pipe
36	145	1500	6	15	1	4	25	Φ102/Φ195	Φ125/Φ218	Cone Pipe
37	126	1400	10.5	15	0.8	3.2	31	Φ130/Φ202	Φ154/Φ226	Cone Pipe
38	126	1400	10.5	15	0.8	3.2	31	Φ130/Φ202	Φ154/Φ226	Cone Pipe
39	126	1400	10.5	15	0.8	3.2	31	Φ130/Φ204	Φ154/Φ226	Cone Pipe
40	126	1400	10.5	15	0.8	3.2	31	Φ130/Φ204	Φ154/Φ226	Cone Pipe
41	72.5	950	5.23	13	1	4	31	Φ102/Φ195	Φ122/Φ215	Cone Pipe
42	72.5	1500	6	15	1	4	31	Φ102/Φ195	Φ125/Φ218	Cone Pipe

Remark:

- 1) All the designs are in accordance with the ANSI/IEC relative standards and can also be customized as per actual request.
- 2) The other type of end fittings are also available if needed.